



(XTR-240-xx)



(XTR-240-xxLA)



(XTR-240-xxPI)

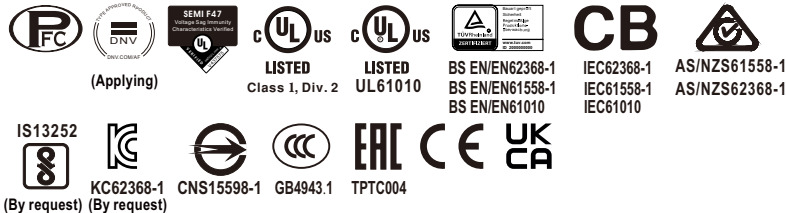

Features

- Three-Phase 320 ~ 600Vac wide range input, 600 ~ 700Vac surge input for 1 sec. occasionally (Dual phase operation possible)
- Global certificates in multi-fields(ITE 62368-1, Industrial 61558-1/-2-16,61010) & Marine DNV, SEMI47, C1D2 HazLoc approved
- 48mm Ultra slim width
- High efficiency up to 93.5% and no load power dissipation <2.5W
- 150% Peak Power capability
- Built-in constant current limiting circuit
- Current sharing up to 960W(3+1) for parallel use (By request)
- Protections: Short circuit / Overload / Over voltage / Over temperature
- Fanless design, cooling by free air convection
- Over voltage category III (OVC III)
- -40~+85°C wide range operation temperature (>+60°C derating)
- Operating altitude up to 5000 meters
- Built-in DC OK relay contact
- Ultra low inrush current < 10A
- Built-in ORing FET (By request)
- Tool free terminal block (LA type)
- Conformal coating
- Can be installed on DIN Rail TS-35/7.5 or 15
- 5 years warranty

Description

The XTR-240 series is a 240W AC/DC 3Ø 320~600Vac input ultra slim industrial high-reliability DIN rail power. Key features of this series include a narrow 48 mm casing, optimizing system installation space, it boasts a maximum efficiency of 93.5% and a low standby power consumption <2.5W for energy savings and carbon reduction. It provides constant current with up to 150% peak power; fanless design, ultra-wide operating temperature range of -40 to +85°C (up to +60°C at full load); OVCIII compliance; parallel function capability up to 960W(By request); ultra-low inrush current of <10A; built-in DC OK and ORing FET(optional); internal PCB coating offers basic moisture and dust protection, and it has multiple terminal blocks for selection. With comprehensive protection functions, complete safety certifications, and a 5-years warranty, the XTR-240 series is a compact, high-performance, and highly reliable DIN rail power supply.

Model Encoding

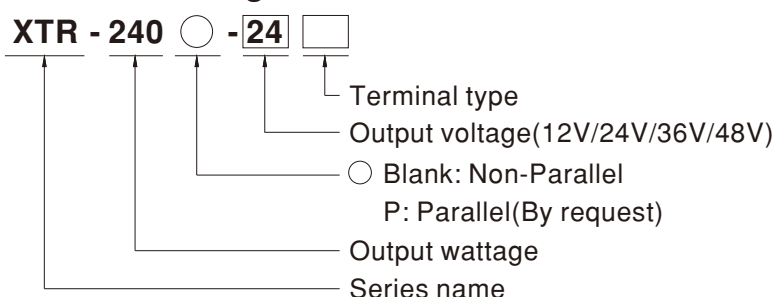

Applications

- Industrial control system
- Semiconductor fabrication equipment
- Factory automation
- Electro-mechanical apparatus

GTIN CODE

MW Search: <https://www.meanwell.com/serviceGTIN.aspx>

Terminal Type Options		Note
Blank	Screw Terminal	In stock
LA	Lever-Actuated	In stock
PI	Push In	In stock



240W AC/DC 3Ø Input Ultra Slim Industrial DIN Rail Power **XTR-240** series

SPECIFICATION	XTR-240○-12□	XTR-240○-24□	XTR-240○-36□	XTR-240○-48□	
	○ =Blank, P □=Blank, LA, PI				
OUTPUT					
DC VOLTAGE	12V	24V	36V	48V	
RATED CURRENT	15A	10A	6.66A	5A	
CURRENT RANGE	0 ~ 15A	0 ~ 10A	0 ~ 6.66A	0 ~ 5A	
RATED POWER	180W	240W	239.8W	240W	
PEAK	CURRENT(5 sec.)	22.5A	15A	10A	7.5A
	POWER(5 sec.)	270W	360W	360W	360W
RIPPLE & NOISE (max.)	Note.2 100mVp-p	100mVp-p	120mVp-p	120mVp-p	
VOLTAGE ADJ. RANGE	12 ~ 15V	24 ~ 29V	36 ~ 42V	48 ~ 55V	
VOLTAGE TOLERANCE	Note.3 ±1.0%	±1.0%	±1.0%	±1.0%	
LINE REGULATION	±0.5%	±0.5%	±0.5%	±0.5%	
LOAD REGULATION	±1.0%	±1.0%	±1.0%	±1.0%	
SETUP, RISE TIME	2000ms, 60ms/400Vac 1500ms, 60ms/500Vac at full load				
HOLD UP TIME (Typ.)	20ms / 400Vac 40ms / 500Vac at full load				
INPUT					
VOLTAGE RANGE	Note.4 Three-Phase 320 ~ 600Vac	450 ~ 800Vdc (Dual phase operation possible in connecting L1,L3,FG or L2,L3,FG)			
NO LOAD POWER CONSUMPTION (Typ.)	2.5W/400Vac	2.5W/400Vac	2.5W/400Vac	2.5W/400Vac	
FREQUENCY RANGE	47 ~ 63Hz				
POWER FACTOR (Typ.)	PF ≥0.53/400Vac PF ≥0.52/500Vac at full load				
EFFICIENCY (Typ.)	88.7%	92.5%	92.5%	93.5%	
AC CURRENT (Typ.)	0.69A/400Vac 0.6A/500Vac				
INRUSH CURRENT (Typ.)	COLD START 10A/400Vac				
LEAKAGE CURRENT	<2mA / 530Vac				
PROTECTION					
OVERLOAD	105%~150% rated output power for more than 5 sec then constant current limiting without shutdown at rate current when Vo=30%~100%				
OVER VOLTAGE	15 ~ 18V	30 ~ 36V	45 ~ 54V	56 ~ 65V	
	Hiccup mode , recovers automatically after fault condition is removed				
OVER TEMPERATURE	Shut down o/p voltage or hiccup mode, recovers automatically after temperature goes down				
FUNCTION					
PARALLEL(Optional)	Up to 960W (3+1), please refer to Function Manual for more details				
DC OK RELAY CONTACT	Relay Contact Ratings (max.):30Vdc/1A, 30Vac/0.5A resistive load				
ENVIRONMENT					
WORKING TEMP.	Note.5 -40 ~ +85°C (Refer to "Derating Curve")				
WORKING HUMIDITY	20 ~ 95% RH non-condensing				
STORAGE TEMP., HUMIDITY	-40 ~ +85°C, 10 ~ 95% RH non-condensing				
TEMP. COEFFICIENT	±0.03%/°C (0 ~ 60°C)				
VIBRATION	Component:10 ~ 500Hz, 2G 10min./1cycle, 60min. each along X, Y, Z axes; Mounting: Compliance to IEC60068-2-6				



240W AC/DC 3Ø Input Ultra Slim Industrial DIN Rail Power **XTR-240** series

SPECIFICATION	XTR-240○-12□	XTR-240○-24□	XTR-240○-36□	XTR-240○-48□
	○ =Blank, P □ =Blank, LA, PI			
SAFETY & EMC Note.7				
SAFETY STANDARDS	UL121201/CSA C22.2 NO.213.17 Class I, Div. 2 Group A, B, C, D Hazardous Locations T4; UL61010; TUV BS EN/EN62368-1, BS EN/EN61558-1/-2-16, BS EN/EN61010; CB IEC62368-1, IEC61558-1, IEC61010; RCM AS/NZS 62368-1, AS/NZS 61558-1/-2-16; BSMI CNS15598-1; CCC GB4943.1; EAC TPTC004 approved; Marine DNV KC KC62368-1 and BIS IS13252 (Part 1):2010 certified, no stock ,contact sale for inquires			
OVER VOLTAGE CATEGORY Note.6	IEC/EN 61558-1/-2-16 (OVC III, altitude up to 2000m) IEC/EN/UL 61010 (OVC II, altitude up to 5000m) IEC/EN 62368-1 (OVC II, altitude up to 5000m)			
SAFETY EXTRA-LOW VOLTAGE(SELV)	IEC/EN 61558-2-16 (SELV 12V/24V) IEC/EN/UL 61010-2-201 (SELV 12V/24V) IEC/EN 62368-1 (SELV/ ES1 12V/24V)			
WITHSTAND VOLTAGE	I/P-O/P:4.87KVac I/P-FG:2.5KVac O/P-FG:0.5KVac O/P-DC OK:0.5KVac			
ISOLATION RESISTANCE	I/P-O/P, I/P-FG, O/P-FG:>100M Ohms / 500VDC / 25°C / 70% RH			
EMC EMISSION	Parameter	Standard		Test Level / Note
	Conducted	BS EN/EN55032(CISPR32) / BS EN/EN61204-3 / CNS15936		Class B
	Radiated	BS EN/EN55032(CISPR32) / BS EN/EN61204-3 / CNS15936		Class B
	Harmonic Current	BS EN/EN61000-3-2		Class A
	Voltage Flicker	BS EN/EN61000-3-3		----
EMC IMMUNITY	BS EN/EN55035 , BS EN/EN61204-3 , BS EN/EN61000-6-2:2005 , BS EN/EN IEC61000-6-2:2019			
	Parameter	Standard		Test Level / Note
	ESD	BS EN/EN61000-4-2		Level 4, 15KV air ; Level 4, 8KV contact
	Radiated Field	BS EN/EN61000-4-3		Level 3, 10V/m ; criteria A
	EFT / Burst	BS EN/EN61000-4-4		Level 4, 4KV ; criteria A
	Surge	BS EN/EN61000-4-5		Level 4, 2KV / Line-Line, Level 4, 4KV/ Line-Earth
	Conducted	BS EN/EN61000-4-6		Level 3, 10V/m ; criteria A
	Magnetic Field	BS EN/EN61000-4-8		Level 4, 30A/m ; criteria A
	Voltage Dips and Interruptions	BS EN/EN61000-4-11		> 95% dip 0.5 periods, 30% dip 25 periods > 95% interruptions 250 periods
OTHERS				
MTBF	1432.3K hrs min. Telcordia SR-332(Bellcore) ; 191.5K hrs min. MIL-HDBK-217F (25°C)			
DIMENSION	48*125.2*125mm (W*H*D)			
PACKING	990g ; 12pcs/12.9Kg/1.16CUFT			
NOTE				
<p>1. All parameters NOT specially mentioned are measured at 400Vac input, rated load and 25°C of ambient temperature.</p> <p>2. Ripple & noise are measured at 20MHz of bandwidth by using a 12" twisted pair-wire terminated with a 0.1 μF & 47 μF parallel capacitor.</p> <p>3. Tolerance : includes set up tolerance, line regulation and load regulation.</p> <p>4. Dual phase operation is allowed under certain derating to output load. Please refer to derating curves for details.</p> <p>5. Installation clearances : 40mm on top, 20mm on the bottom, 5mm on the left and right side are recommended when loaded permanently with full power. In case the adjacent device is a heat source, 15mm clearance is recommended.</p> <p>6. The ambient temperature derating of 3.5°C/1000m with fanless models and of 5°C/1000m with fan models for operating altitude higher than 2000m(6500ft).</p> <p>7. The power supply is considered as an independent unit, but the final equipment still need to re-confirm that the whole system complies with the EMC directives. For guidance on how to perform these EMC tests, please refer to "EMI testing of component power supplies." (as available on https://www.meanwell.com/Upload/PDF/EMI_statement_en.pdf)</p> <p>※ Product Liability Disclaimer : For detailed information, please refer to https://www.meanwell.com/serviceDisclaimer.aspx</p>				

Block Diagram

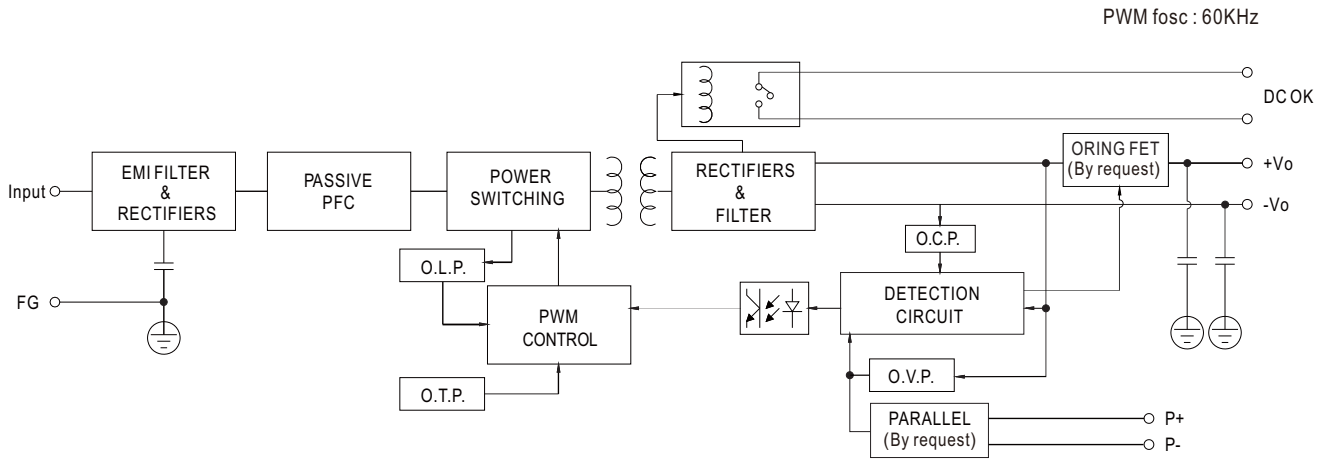

Derating Curve

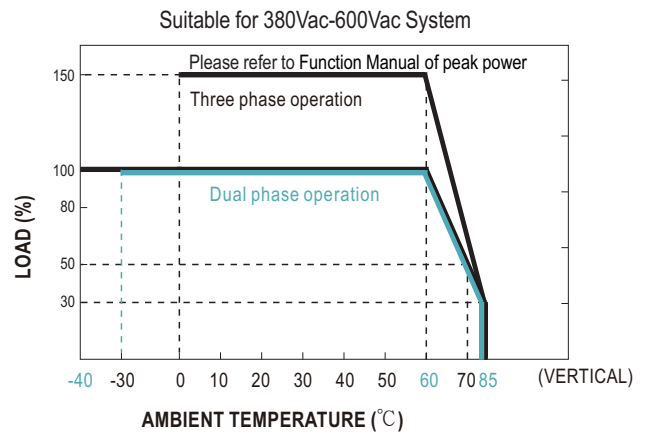
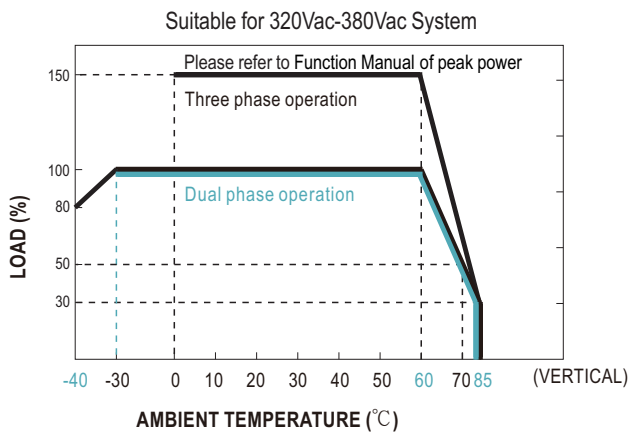

Note : Dual phase operating temperature is between -30°C~+85°C.

Output derating VS input voltage

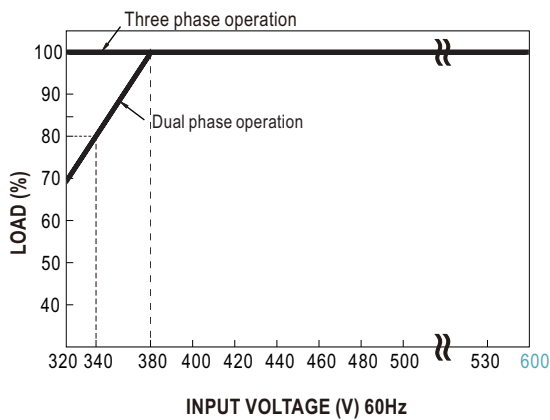

Note : When ambient temperature is between -30°C~-10°C and unit is operated in dual-phase input mode :
 - At dual-phase input 320~380Vac, power supply can be loaded but might experience hiccup at cold start for 5~10 seconds.

■ Peak Power

$$P_{av} = \frac{P_{pk} \times t + P_{npk} \times (T-t)}{T} \leq P_{rated}$$

$$Duty = \frac{t}{T} \times 100\% \leq 35\%$$

$$t \leq 5 \text{ sec}$$

P_{av} : Average output power (W)

P_{pk} : Peak output power (W)

P_{npk} : Non-peak output power (W)

P_{rated} : Rated output power (W)

t : Peak power width(sec)

T : Period(sec)

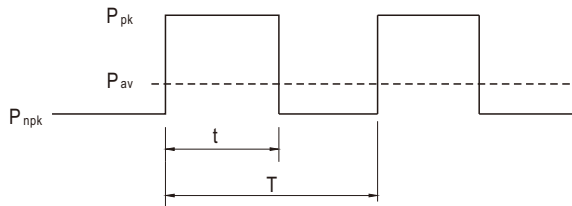

— 3Ø 320 ~ 600Vac

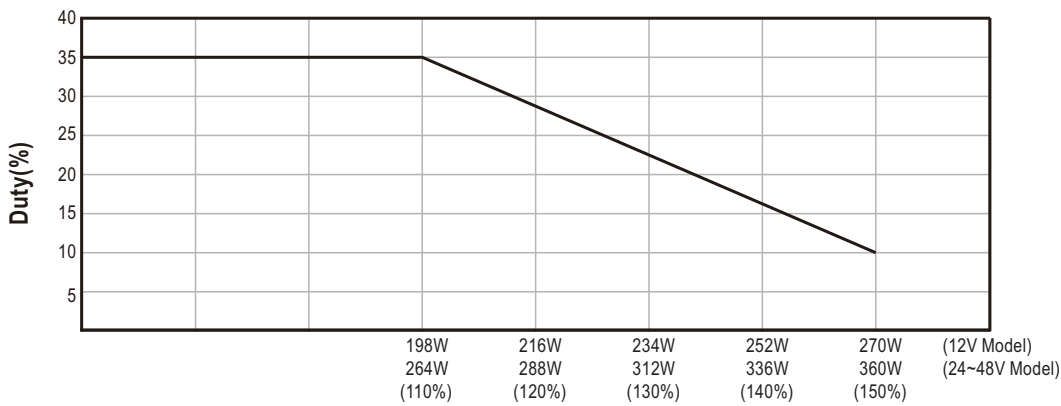

Peak output power (W)

For example (24V model) :

$V_{in} = 400V$ $Duty_{max} = 10\%$

$P_{av} = P_{rated} = 240W$

$P_{pk} = 360W$

$t \leq 5 \text{ sec}$

$$T \geq \frac{5 \text{ sec}}{10\%} \geq 50 \text{ sec}$$

$$P_{npk} \leq \frac{T P_{av} - t P_{pk}}{T-t}$$

$P_{npk} \leq 226W$

■ Function Manual

Pin No.	Function	Description
1,2	DC OK	Contact close : PSU turns ON/DC_OK ; Contact open : PSU turns OFF/DC_fail; Contact ratings (max.): 30Vdc/1A ,30Vac/0.5A resistive load.
3	P+ (By request)	Current sharing signal. When units are connected in parallel, the P+ pins of the units should be connected mutually to allow current balance between units.
4	P- (By request)	Current sharing signal. When units are connected in parallel, the P- pins of the units should be connected mutually to allow current balance between units. P- Signal is internally connected to -Vo.

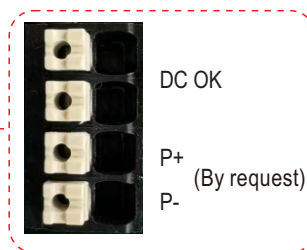
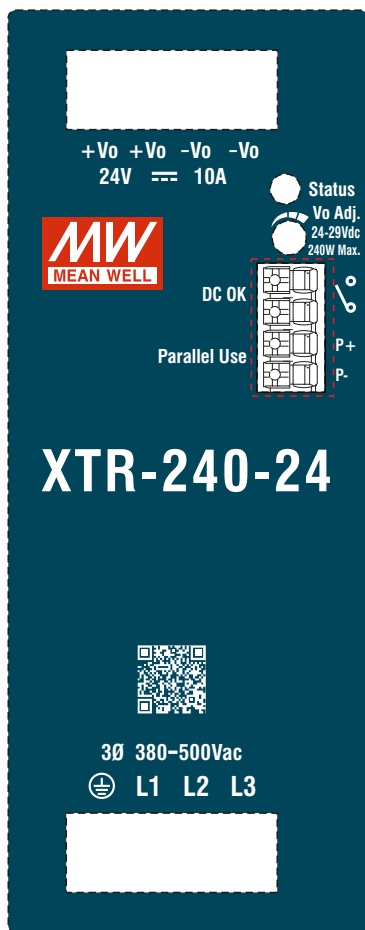

1.Parallel Use (By request)

XTR-240 has the built-in active current sharing function and can be connected in parallel, up to 4 units, to provide higher output power as exhibited below :

- (1) Parallel operation is available by connecting the units shown as below (P+,P- are connected mutually in parallel).
- (2) Difference of output voltages among parallel units should be less than 0.2V.
- (3) The total output current must not exceed the value determined by the following equation (Output current at parallel operation)=(The rated current per unit) x (Number of unit) x 0.9.
- (4) In parallel operation 4 units is the maximum, please consult the manufacture for other applications.
- (5) The power supplies should be paralleled using short and large diameter wiring and then connected to the load.
- (6) When in parallel operation, the minimum output load should be greater than 5% of total output load. (Min. load >5% rated current per unit x number of unit)
- (7) P+ and P- lines should be twisted in pairs

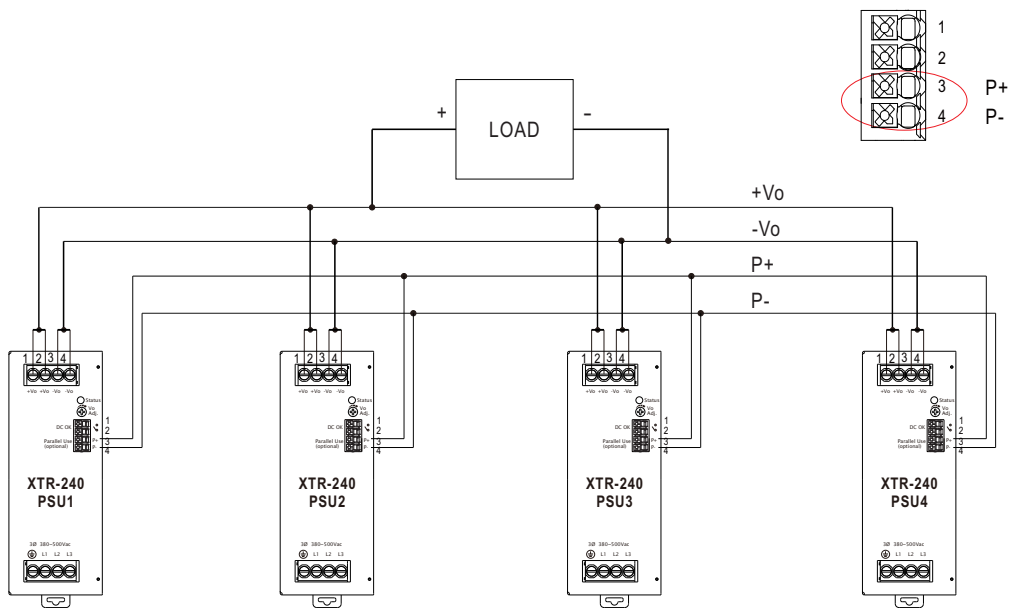

※ Please contact MEAN WELL for more details.

2.DC OK Relay Contact

Contact Close	PSU turns ON / DC OK.
Contact Open	PSU turns OFF / DC Fail.
Contact ratings (max.)	30Vdc/1A ,30Vac/0.5A resistive load.

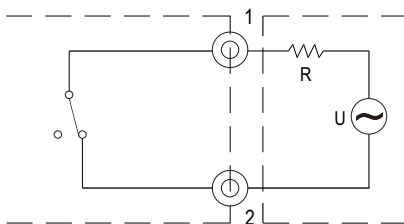
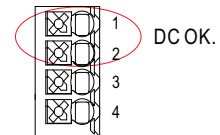

External voltage source (U) and resistor (R)
(The max. Sink is 30Vdc/1A,30Vac/0.5A)

Internal circuit of DC_OK, via relay contact

3. Protection Against Inverse Reverse From The Load (By request)

Prevent PSU damage from Back Electro magnetic Force during deceleration of motor or inductive load.

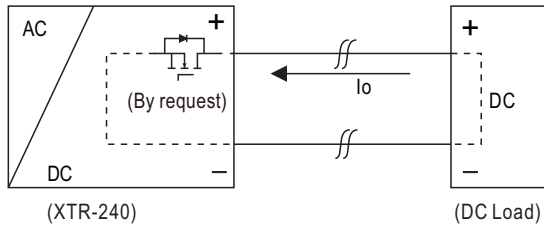

PSU'S ORing FET turn OFF voltage	
MODEL	Max. allowable reverse voltage
XTR-240-12	<16V
XTR-240-24	<35V
XTR-240-36	<50V
XTR-240-48	<63V

■ Mechanical Specification

(Unit:mm , Tolerance ±1mm)

Case No. 303

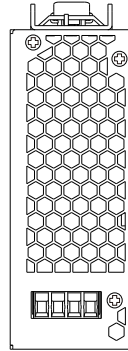

Ⓐ : Terminal Pin No. Assignment

Pin No.	Assignment
1,2	DC Output +Vo
3,4	DC Output -Vo

Ⓑ : Control Pin No. Assignment

Pin No.	Assignment
1,2	DC OK Relay Contact
3	P+(Current sharing,By request)
4	P-(Current sharing,By request)

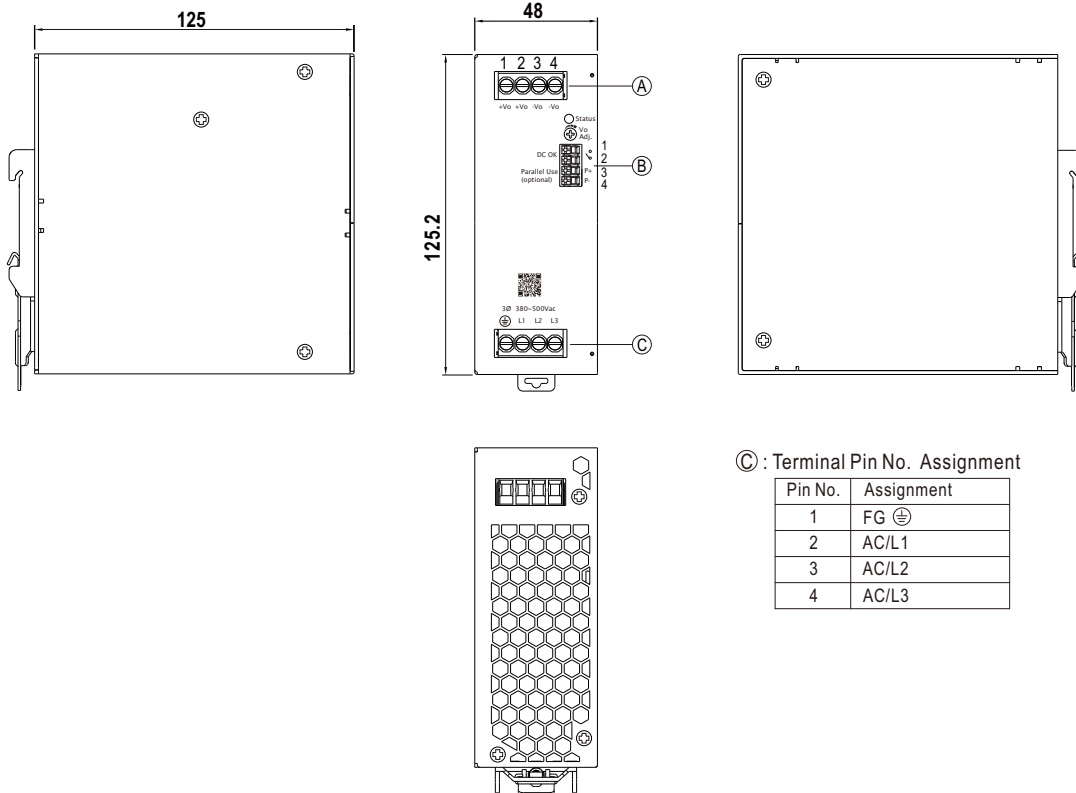

Ⓒ : Terminal Pin No. Assignment

Pin No.	Assignment
1	FG Ⓧ
2	AC/L1
3	AC/L2
4	AC/L3

■ Recommend Wiring

※ Screw Terminal Torque

		AC Input T.B	DC Output T.B	Signal connector
Solid Wire		6mm ² max.	6mm ² max.	1.5mm ² max.
A.W.G	XTR-240-12	18~10 AWG	12~10 AWG	24~16 AWG
	XTR-240-24/36/48		16~10 AWG	
Wire Stripping Length		10~11mm	10~11mm	8~9mm
Screw Terminal Torque		5 Lb-In	5 Lb-In	/

※ Lever-Actuated and Push In

		AC Input T.B	DC Output T.B	Signal connector
Solid Wire		6mm ² max.	6mm ² max.	1.5mm ² max.
A.W.G	XTR-240-12	18~10 AWG	12~10 AWG	24~16 AWG
	XTR-240-24/36/48		16~10 AWG	
Wire Stripping Length		10~11mm	10~11mm	8~9mm
Screw Terminal Torque		Not applicable		

■ Installation Instruction

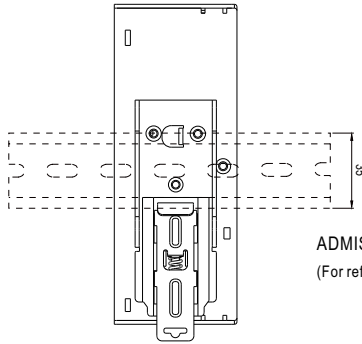

This series fits DIN rail TS35/7.5 or TS35/15.
For installation details, please refer to the Instruction manual.

ADMISSIBLE DIN-RAIL: TS35/7.5 OR TS35/15
(For reference only. Not included with unit.)

■ Installation Manual

Please refer to : <http://www.meanwell.com/manual.html>