

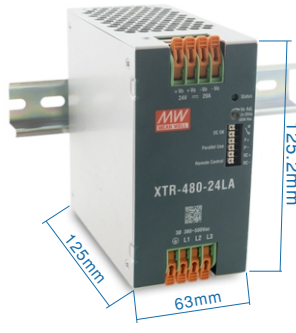

(XTR-480-xx)



(XTR-480-xxLA)



(XTR-480-xxPI)

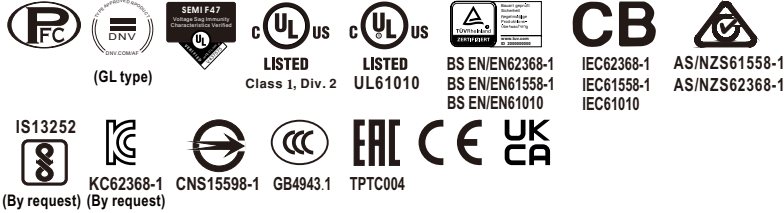

■ Features

- Three-Phase 320 ~ 600Vac wide range input (Dual phase operation possible)
- Global certificates in multi-fields(ITE 62368-1, Industrial 61558-1/-2-16,61010) & Marine DNV, SEMI47, C1D2 HazLoc approved
- 63mm Ultra slim width
- High efficiency up to 95.5% and no load power dissipation <3.0W by R.C.
- 200% Peak Power capability
- Built-in constant current limiting circuit
- Current sharing up to 1920W(3+1) for parallel use
- Protections: Short circuit / Overload / Over voltage / Over temperature
- Fanless design, cooling by free air convection
- Over voltage category III (OVC III)
- -40~+85°C wide range operation temperature (>+60°C derating)
- Operating altitude up to 5000 meters
- Built-in Remote ON/OFF Control and DC OK relay contact
- Ultra low inrush current < 10A
- Built-in ORing FET
- Tool free terminal block (LA type)
- Conformal coating
- Can be installed on DIN Rail TS-35/7.5 or 15
- 5 years warranty

■ Description

The XTR-480 series is a 480W AC/DC 3Ø 320~600Vac input ultra slim industrial high-reliability DIN rail power. Key features of this series include a narrow 63 mm casing, optimizing system installation space, it boasts a maximum efficiency of 95.5% and a low standby power consumption <3.0W by remote control for energy savings and carbon reduction. It provides constant current with up to 200% peak power; fanless design, ultra-wide operating temperature range of -40 to +85°C (up to +60°C at full load); OVCIII compliance; parallel function capability up to 1920W; ultra-low inrush current of <10A; built-in Remote Control, DC OK and ORing FET; internal PCB coating offers basic moisture and dust protection, and it has multiple terminal blocks for selection. With comprehensive protection functions, complete safety certifications, and a 5-years warranty, the XTR-480 series is a compact, high-performance, and highly reliable DIN rail power supply.

■ Model Encoding

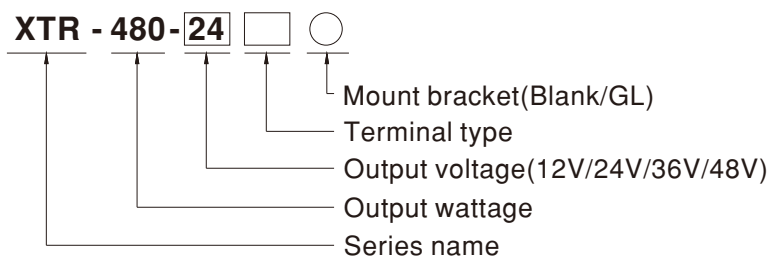

■ Applications

- Industrial control system
- Semiconductor fabrication equipment
- Factory automation
- Electro-mechanical apparatus

■ GTIN CODE

MW Search: <https://www.meanwell.com/serviceGTIN.aspx>

Terminal Type Options		Note
Blank	Screw Terminal	In stock
LA	Lever-Actuated	In stock
PI	Push In	In stock



480W AC/DC 3Ø Input Ultra Slim Industrial DIN Rail Power **XTR-480** series

SPECIFICATION		XTR-480-12□○	XTR-480-24□○	XTR-480-36□○	XTR-480-48□○
		□=Blank, LA, PI ○=Blank, GL			
OUTPUT					
DC VOLTAGE		12V	24V	36V	48V
RATED CURRENT		30A	20A	13.3A	10A
CURRENT RANGE		0 ~ 30A	0 ~ 20A	0 ~ 13.3A	0 ~ 10A
RATED POWER		360W	480W	478.8W	480W
PEAK	CURRENT(5 sec.)	60A	40A	26.7A	20A
	POWER(5 sec.)	720W	960W	961W	960W
RIPPLE & NOISE (max.) <small>Note.2</small>		120mVp-p	120mVp-p	150mVp-p	150mVp-p
VOLTAGE ADJ. RANGE		12 ~ 15V	24 ~ 29V	36 ~ 42V	48 ~ 55V
VOLTAGE TOLERANCE <small>Note.3</small>		±2.0%	±1.0%	±1.0%	±1.0%
LINE REGULATION		±0.5%	±0.5%	±0.5%	±0.5%
LOAD REGULATION		±1.0%	±1.0%	±1.0%	±1.0%
SETUP, RISE TIME		800ms, 60ms/400Vac 600ms, 60ms/500Vac at full load			
HOLD UP TIME (Typ.)		20ms / 400Vac 20ms / 500Vac at full load			
INPUT					
VOLTAGE RANGE <small>Note.4</small>		Three-Phase 320 ~ 600Vac (Dual phase operation possible) 450 ~ 800Vdc			
NO LOAD POWER CONSUMPTION (Typ.)	Remote Power OFF	3.0W/400Vac	3.0W/400Vac	3.0W/400Vac	3.0W/400Vac
	Remote Power ON	5.0W/400Vac	5.0W/400Vac	5.0W/400Vac	5.0W/400Vac
FREQUENCY RANGE		47 ~ 63Hz			
POWER FACTOR (Typ.)		PF ≥ 0.9/400Vac PF ≥ 0.88/500Vac at full load			
EFFICIENCY (Typ.)		93%	94%	94.5%	95.5%
AC CURRENT (Typ.)		0.85A/400Vac 0.7A/500Vac			
INRUSH CURRENT (Typ.)		COLD START 10A/500Vac			
LEAKAGE CURRENT		<3.5mA / 530Vac			
PROTECTION					
OVERLOAD		105%~200% rated output power for more than 5 sec then constant current limiting without shutdown at rate current when Vo=30%~100%			
OVER VOLTAGE		15 ~ 18V	30 ~ 35V	43 ~ 50V	56 ~ 65V
		Protection type : Shut down o/p voltage, re-power on to recover			
OVER TEMPERATURE		Shut down o/p voltage or hiccup mode, recovers automatically after temperature goes down			
FUNCTION					
PARALLEL		Up to 1920W (3+1), please refer to Function Manual for more details			
DC OK RELAY CONTACT		Relay Contact Ratings (max.):30Vdc/1A, 30Vac/0.5A resistive load			
REMOTE CONTROL		Power ON : RC + ~ RC- open or keep 2~5Vdc			
		Power OFF: RC + ~ RC- short or keep<0.5Vdc			
ENVIRONMENT					
WORKING TEMP. <small>Note.5</small>		-40 ~ +85°C (Refer to "Derating Curve")			
WORKING HUMIDITY		20 ~ 95% RH non-condensing			
STORAGE TEMP., HUMIDITY		-40 ~ +85°C, 10 ~ 95% RH non-condensing			
TEMP. COEFFICIENT		±0.03%/°C (0 ~ 60°C)			
VIBRATION		Component:10 ~ 500Hz, 2G 10min./1cycle, 60min. each along X, Y, Z axes; Mounting: Compliance to IEC60068-2-6			



480W AC/DC 3Ø Input Ultra Slim Industrial DIN Rail Power **XTR-480** series

SPECIFICATION	XTR-480-12 □○	XTR-480-24 □○	XTR-480-36 □○	XTR-480-48 □○
	□=Blank, LA, PI ○=Blank, GL			
SAFETY & EMC Note.7				
SAFETY STANDARDS	UL121201/CSA C22.2 NO.213.17 Class I, Div. 2 Group A, B, C, D Hazardous Locations T4; UL61010; TUV BS EN/EN62368-1, BS EN/EN61558-1/-2-16, BS EN/EN61010; CB IEC62368-1, IEC61558-1, IEC61010; RCM AS/NZS 62368-1, AS/NZS 61558-1/-2-16; BSMI CNS15598-1; CCC GB4943.1; EAC TPTC004 approved; Marine DNV (for GL type only) KC KC62368-1 and BIS IS13252 (Part 1):2010 certified, no stock ,contact sale for inquires			
OVER VOLTAGE CATEGORY Note.6	IEC/EN 61558-1/-2-16 (OVC III, altitude up to 2000m) IEC/EN/UL 61010 (OVC II, altitude up to 5000m) IEC/EN 62368-1 (OVC II, altitude up to 5000m)			
SAFETY EXTRA-LOW VOLTAGE(SELV)	IEC/EN 61558-2-16 (SELV) IEC/EN/UL 61010-2-201 (SELV) IEC/EN 62368-1 (SELV/ ES1)			
WITHSTAND VOLTAGE	I/P-O/P:4.87KVac I/P-FG:2.5KVac O/P-FG:0.5KVac O/P-DC OK:0.5KVac			
ISOLATION RESISTANCE	I/P-O/P, I/P-FG, O/P-FG:>100M Ohms / 500VDC / 25°C / 70% RH			
EMC EMISSION	Parameter	Standard		Test Level / Note
	Conducted	BS EN/EN55032(CISPR32) / BS EN/EN61204-3 / CNS15936		Class B
	Radiated	BS EN/EN55032(CISPR32) / BS EN/EN61204-3 / CNS15936		Class B
	Harmonic Current	BS EN/EN61000-3-2		Class A
	Voltage Flicker	BS EN/EN61000-3-3		----
EMC IMMUNITY	BS EN/EN55035 , BS EN/EN61204-3 , BS EN/EN61000-6-2:2005 , BS EN/EN IEC61000-6-2:2019			
	Parameter	Standard		Test Level / Note
	ESD	BS EN/EN61000-4-2		Level 4, 15KV air ; Level 4, 8KV contact
	Radiated Field	BS EN/EN61000-4-3		Level 3, 10V/m ; criteria A
	EFT / Burst	BS EN/EN61000-4-4		Level 4, 4KV ; criteria A
	Surge	BS EN/EN61000-4-5		Level 4, 2KV / Line-Line, Level 4, 4KV/ Line-Earth
	Conducted	BS EN/EN61000-4-6		Level 3, 10V/m ; criteria A
	Magnetic Field	BS EN/EN61000-4-8		Level 4, 30A/m ; criteria A
	Voltage Dips and Interruptions	BS EN/EN61000-4-11		> 95% dip 0.5 periods, 30% dip 25 periods > 95% interruptions 250 periods
OTHERS				
MTBF	1267.7K hrs min. Telcordia SR-332(Bellcore) ; 167.4K hrs min. MIL-HDBK-217F (25°C)			
DIMENSION	63*125.2*125mm (W*H*D)			
PACKING	1.18Kg ; 8pcs/11.2Kg/1.28CUFT			
NOTE				
1. All parameters NOT specially mentioned are measured at 400Vac input, rated load and 25°C of ambient temperature. 2. Ripple & noise are measured at 20MHz of bandwidth by using a 12" twisted pair-wire terminated with a 0.1 μF & 47 μF parallel capacitor. 3. Tolerance : includes set up tolerance, line regulation and load regulation. 4. Dual phase operation is allowed under certain derating to output load. Please refer to derating curves for details. 5. Installation clearances : 40mm on top, 20mm on the bottom, 5mm on the left and right side are recommended when loaded permanently with full power. In case the adjacent device is a heat source, 15mm clearance is recommended. 6. The ambient temperature derating of 3.5°C/1000m with fanless models and of 5°C/1000m with fan models for operating altitude higher than 2000m(6500ft). 7. The power supply is considered as an independent unit, but the final equipment still need to re-confirm that the whole system complies with the EMC directives. For guidance on how to perform these EMC tests, please refer to "EMI testing of component power supplies." (as available on https://www.meanwell.com/Upload/PDF/EMI_statement_en.pdf) ※ Product Liability Disclaimer : For detailed information, please refer to https://www.meanwell.com/serviceDisclaimer.aspx				

■ Block Diagram

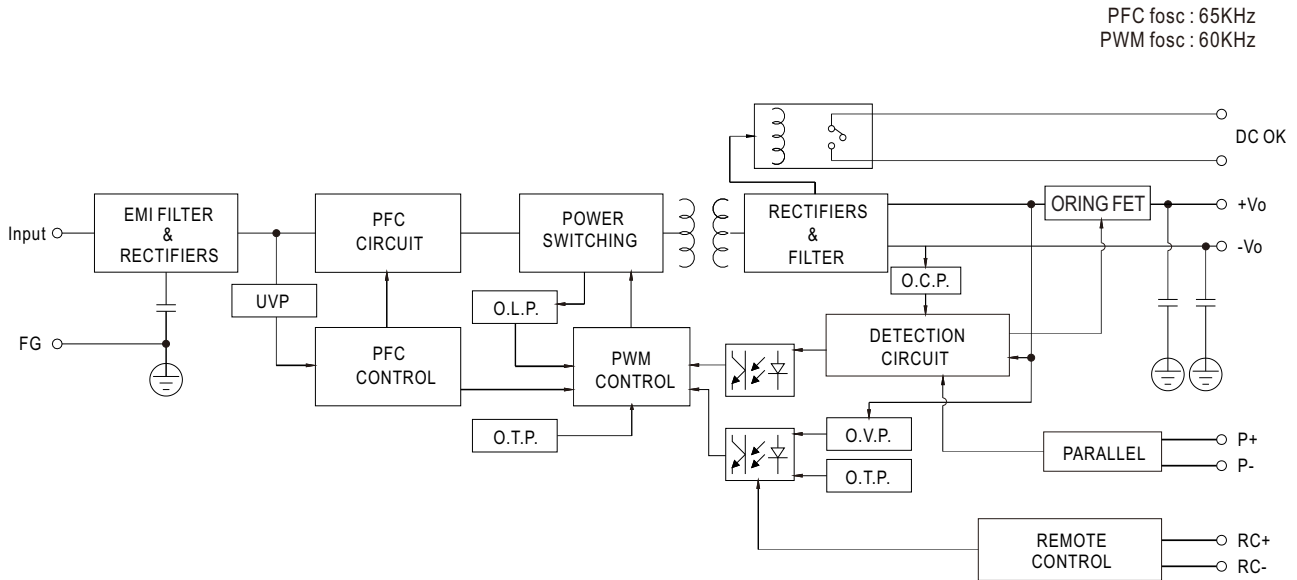

■ Derating Curve

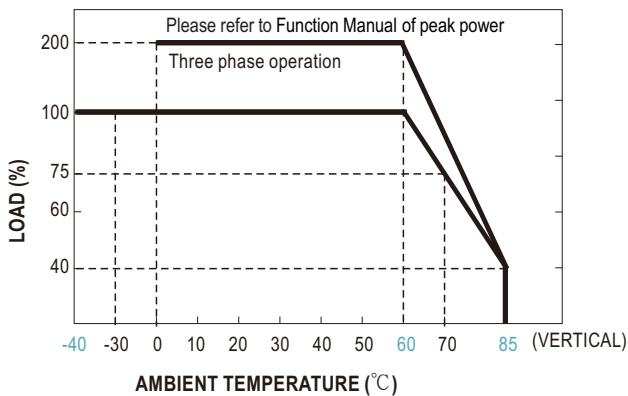

■ Output derating VS input voltage

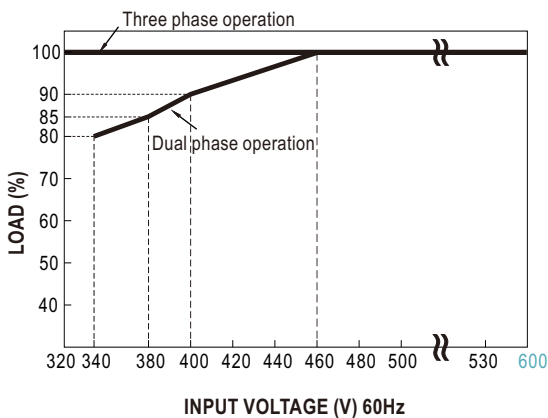

■ Peak Power

$$P_{av} = \frac{P_{pk} \times t + P_{npk} \times (T-t)}{T} \leq P_{rated}$$

$$Duty = \frac{t}{T} \times 100\% \leq 35\%$$

$$t \leq 5 \text{ sec}$$

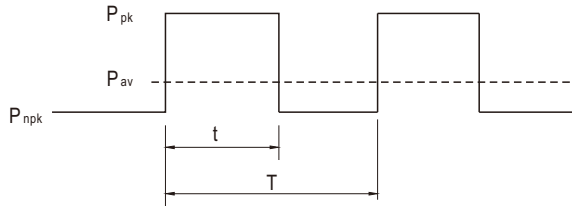

P_{av} : Average output power (W)

P_{pk} : Peak output power (W)

P_{npk} : Non-peak output power (W)

P_{rated} : Rated output power (W)

t : Peak power width (sec)

T : Period (sec)

— 3Ø 320 ~ 600Vac

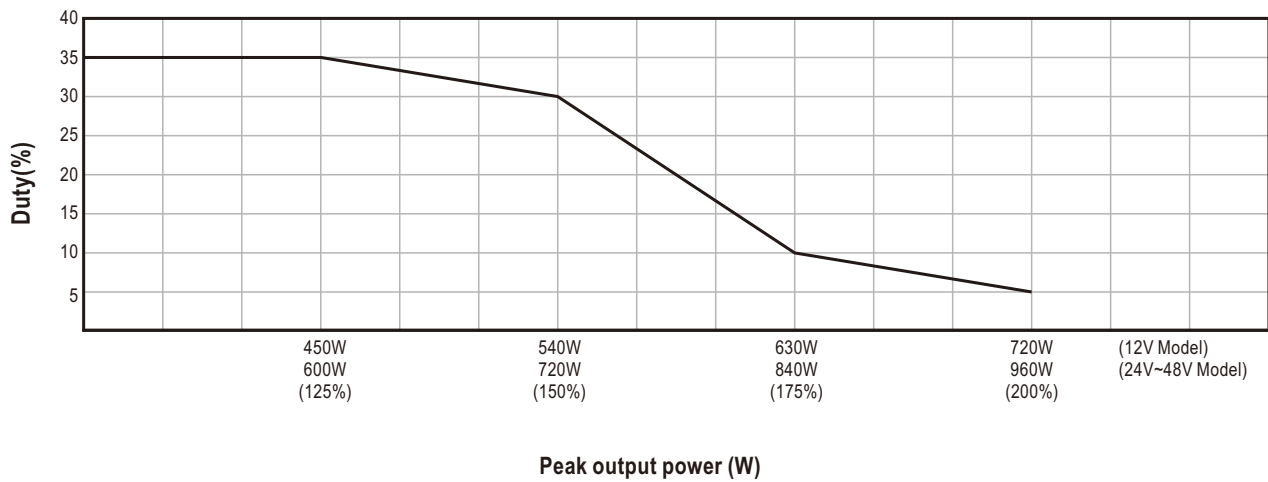

For example (24V model) :

$V_{in} = 400V$ $Duty_{max} = 5\%$

$P_{av} = P_{rated} = 480W$

$P_{pk} = 960W$

$t \leq 5 \text{ sec}$

$$T \geq \frac{5 \text{ sec}}{5\%} \geq 100 \text{ sec}$$

$$P_{npk} \leq \frac{T P_{av} - t P_{pk}}{T-t}$$

$$P_{npk} \leq 454.7W$$

■ Function Manual

Pin No.	Function	Description
1,2	DC OK Relay Contact	Contact close : PSU turns ON/DC_OK ; Contact open : PSU turns OFF/DC_fail; Contact ratings (max.): 30Vdc/1A ,30Vac/0.5A resistive load.
3	P+	Current sharing signal. When units are connected in parallel, the P+ pins of the units should be connected mutually to allow current balance between units.
4	P-	Current sharing signal. When units are connected in parallel, the P- pins of the units should be connected mutually to allow current balance between units. P- Signal is internally connected to -Vo.
5	RC+	Turns the output ON and OFF by electrical signal Remote power ON : Open or keep 2~5Vdc
6	RC-	Remote power OFF: Short or keep<0.5Vdc

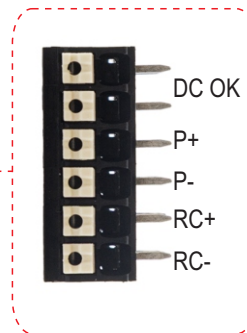
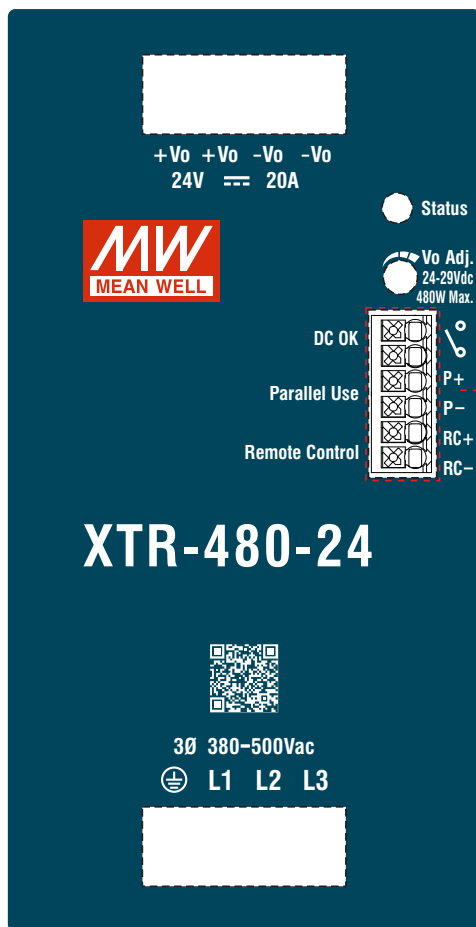

1.Parallel Use

XTR-480 has the built-in active current sharing function and can be connected in parallel, up to 4 units, to provide higher output power as exhibited below :

- (1) Parallel operation is available by connecting the units shown as below (P+,P- are connected mutually in parallel).
- (2) Difference of output voltages among parallel units should be less than 0.2V.
- (3) The total output current must not exceed the value determined by the following equation (Output current at parallel operation)=(The rated current per unit) x (Number of unit) x 0.9.
- (4) In parallel operation 4 units is the maximum, please consult the manufacture for other applications.
- (5) The power supplies should be paralleled using short and large diameter wiring and then connected to the load.
- (6) When in parallel operation, the minimum output load should be greater than 5% of total output load. (Min. load >5% rated current per unit x number of unit)
- (7) P+ and P- lines should be twisted in pairs

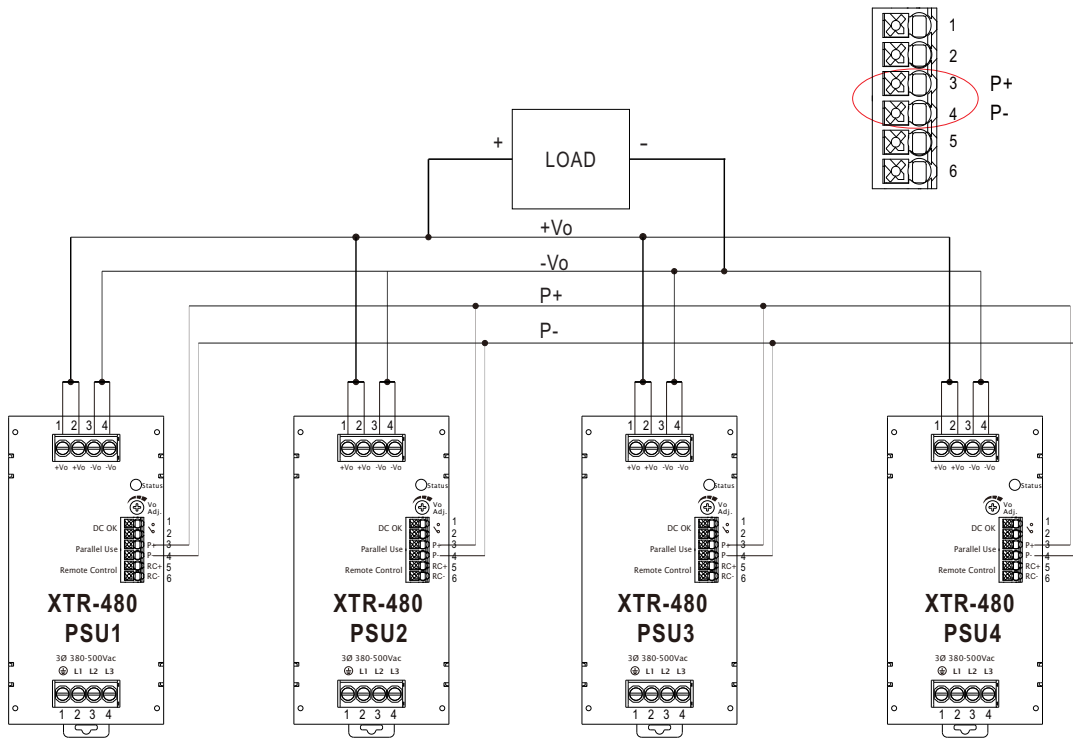

※ Please contact MEAN WELL for more details.

2.DC OK Relay Contact

Contact Close	PSU turns ON / DC OK.
Contact Open	PSU turns OFF / DC Fail.
Contact ratings (max.)	30Vdc/1A ,30Vac/0.5A resistive load.

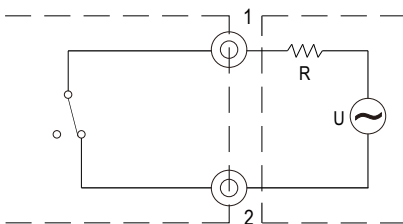
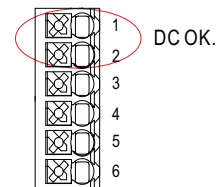

External voltage source (U) and resistor (R)
(The max. Sink is 30Vdc/1A ,30Vac/0.5A)

Internal circuit of DC_OK, via relay contact

3. Remote ON/OFF Control

The PSU can be turned ON/OFF by using the "Remote Control" function.

PSU Vo Status	Between RC+ and RC-
Remote power ON	Open or keep 2~5Vdc
Remote power OFF	Short or keep <0.5Vdc

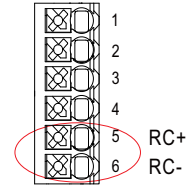

R.C. by external switch .	R.C. by user's optocoupler control module.	R.C. by user's external auxiliary power .	R.C. by user's Relay control module.

4. Protection Against Reverse Voltages from the Load

Prevent PSU damage from Back Electro magnetic Force during deceleration of motor or inductive load.

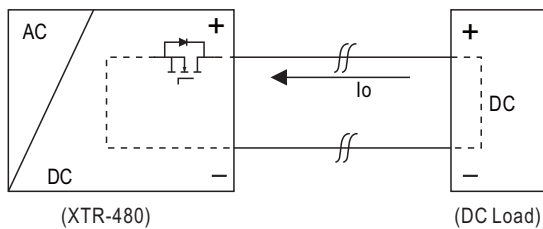

PSU'S ORing FET turn OFF voltage	
MODEL	Max. allowable reverse voltage
XTR-480-12	<16V
XTR-480-24	<35V
XTR-480-36	<50V
XTR-480-48	<63V

■ Mechanical Specification

(Unit:mm , Tolerance ±1mm)

Case No.305

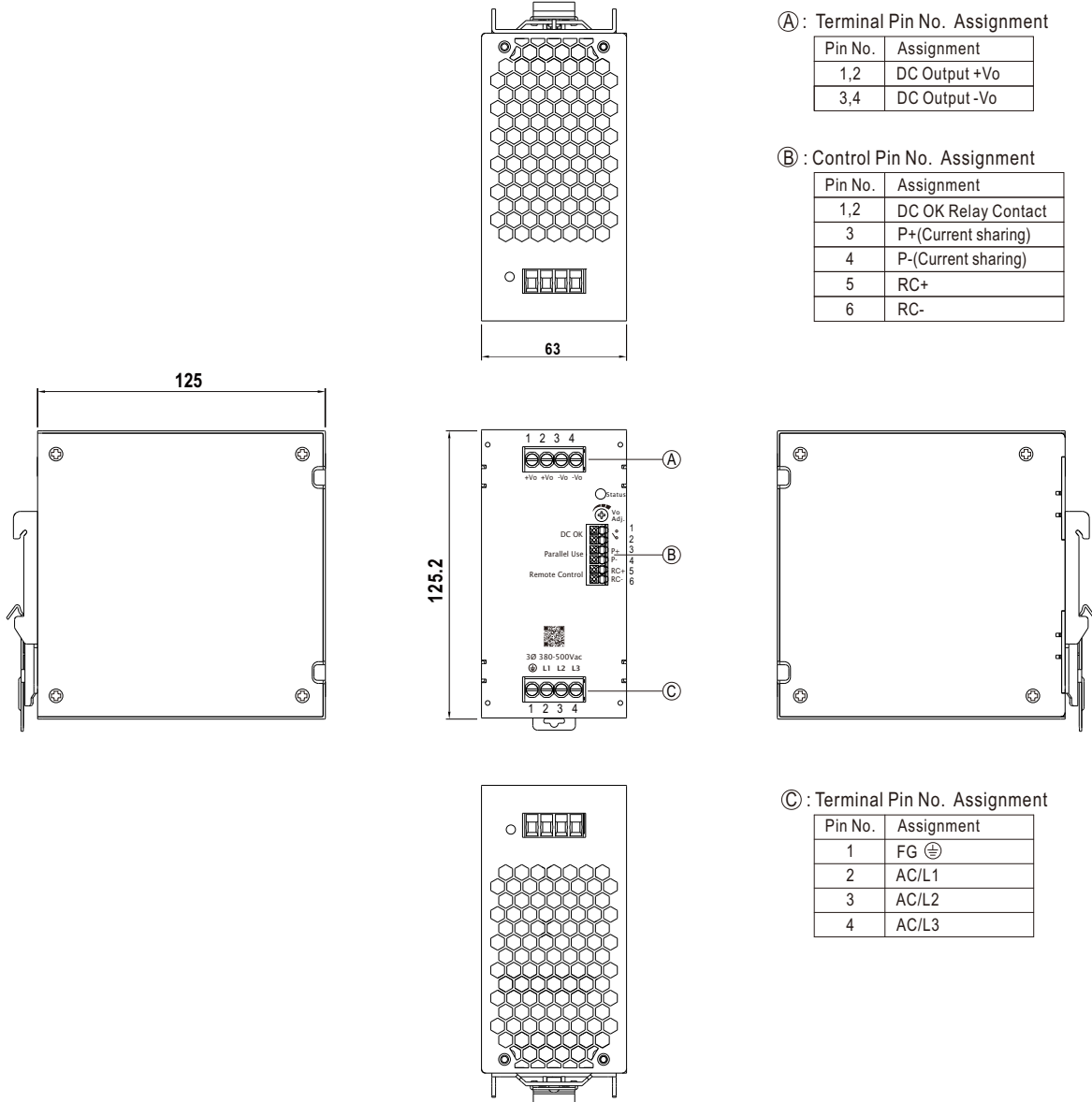

■ Recommend Wiring

※ Screw Terminal Torque



		AC Input T.B	DC Output T.B	Signal connector
Solid Wire		6mm ² max.	6mm ² max.	1.5mm ² max.
A.W.G	XTR-480-12	18~10 AWG	12~10 AWG	24~16 AWG
	XTR-480-24/36/48		16~10 AWG	
Wire Stripping Length		10~11mm	10~11mm	8~9mm
Screw Terminal Torque		5 Lb-In	5 Lb-In	/

※ Lever-Actuated and Push In

		AC Input T.B	DC Output T.B	Signal connector
Solid Wire		6mm ² max.	6mm ² max.	1.5mm ² max.
A.W.G	XTR-480-12	18~10 AWG	12~10 AWG	24~16 AWG
	XTR-480-24/36/48		16~10 AWG	
Wire Stripping Length		10~11mm	10~11mm	8~9mm
Screw Terminal Torque		Not applicable		

■ Accessory List and Installation Diagram for GL Type

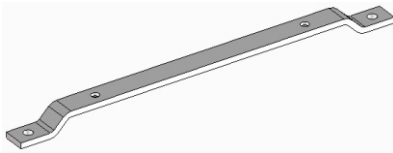
- The GL Type model is recommended for GNV certification or high vibration application.
- The GL Type model include the following accessories.

NO.	Item		Quantity
1	GL installation bracket		2
2	Screw(M3*8)		4
3	Screw(M4*8)		4

※ GL Type mechanical specification

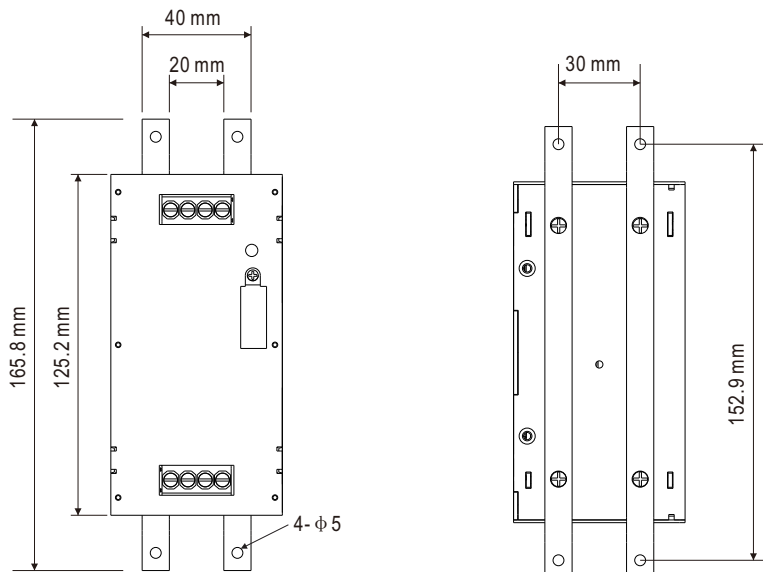

※ GL Type installation steps

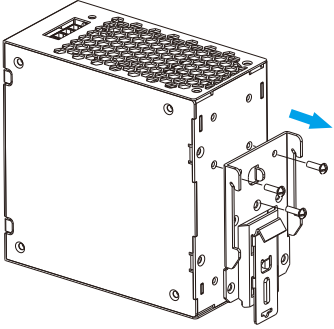
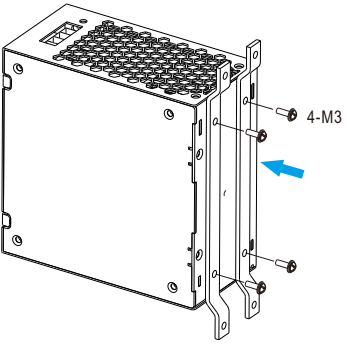
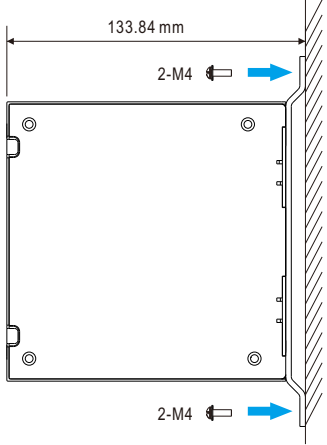
Step1	Step2	Step3
		
<p>Detach the DIN Rail clip by removing screws.</p>	<p>Mount the steel brackets to the back of the case with M3*8 (L=8mm) screws. Recommended screw torque setting is 5 Lb-In.</p>	<p>Mount the XTR-480 power supply directly to the wall/panel through the mounting holes on the brackets.</p>

■ DIN Rail Type Installation

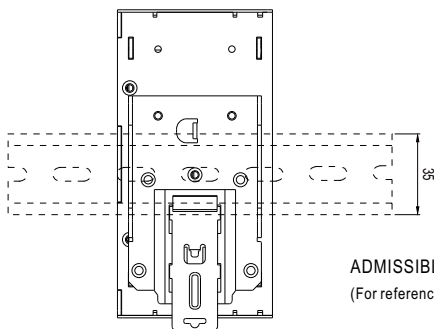

This series fits DIN rail TS35/7.5 or TS35/15.
For installation details, please refer to the Instruction manual.

ADMISSIBLE DIN-RAIL: TS35/7.5 OR TS35/15
(For reference only. Not included with unit.)

■ Installation Manual

Please refer to : <http://www.meanwell.com/manual.html>