

# ETIREL Electromechanical Relays

## Electromechanical power relays RERM3



### Application

Electromechanical relays RERM are designed for switching, control and signaling of auxiliary and power circuits.

### Features

- // 3 changeover contacts;
- // Control voltages AC 24V, AC 230V;
- // Test button without blocking
- // Base for relay RERB3-S (DIN rail mounting TH-35);
- // Accessories: (metal bracket-holder RER-CLIP-SP);

### Electromagnetic Plugin Relays with Mechanical Indication Test Button



Type	Code	Uc rated coil voltage [V]	Indication	No. Of contacts		
RERM3-230AC	002473060	230 V AC	-	3 x CO	80	1/100
RERM3-230ACL	002473061	230 V AC	LED	In=16A	80	1/100
RERM3-024AC	002473062	24V AC	-	AC1, 250V AC)	80	1/100
RERM3-024ACL	002473063	24V AC	LED		80	1/100



RERM3-230AC

- // Screw terminals (max torque 0.7 Nm);



### Plug-in Sockets (Base)

Type	Code	For use with		
RERB3-S	002473064	RERM3	70	1/250



RERB3-S

### Accessories

Type	Code	For use with		
RER-CLIP-SP	002473065	RERB3-S	-	1/1000



RER-CLIP-SP

**Table 1: Technical data**

		RERM3
<b>Contact Data</b>		
Number and type of contacts		3 CO
Contact material		AgNi
Rated / max. switching voltage	AC	440 V
Min. switching voltage		5 V
Rated load (capacity)		16 A / 250 V AC 10 A / 400 V AC
Min. switching current		5 mA
Max. inrush current		40 A
Rated current		16 A
Max. breaking capacity	AC1	4000 VA
Min. breaking capacity		0.3 W
Contact resistance		≤ 100 mΩ
<b>Max. operating frequency (cycles/hour)</b>		
• at rated load	AC1	1 200
• no load		12 000
<b>Coil data</b>		
Rated voltage		AC: 24V, 240V
Must release voltage		AC: ≥ 0,15 Un
Operating range of supply voltage		see next page
Rated power consumption		2,8 VA (50Hz) / 2,5 VA (60Hz)
<b>Insulation according to EN 60664-1</b>		
Insulation rated voltage		400 V AC
Rated surge voltage		4 000 V 1,2 / 50 μs
Overvoltage category		III
Insulation pollution degree		2
Dielectric strength between coil and contacts (basic insulation)		2500 V AC
Dielectric strength - contact clearance		
- micro disconnection		1500 V AC
- full disconnection with contact gap ≥ 3mm		2500 V AC
Dielectric strength pole-pole (basic insulation)		2500 V AC
<b>Contact - coil distance</b>		
- Clearance		≥ 5 mm 2CO, 2NO 35 g ≥ 4 mm 3CO, 3NO
- Creepage		≥ 8 mm 2CO, 2NO ≥ 5 mm 3CO, 3NO
<b>General data</b>		
Operating / release time (typical values)		20 ms / 15 ms
<b>Electrical life</b>		
- Resistive AC1		>10 <sup>5</sup> 16 A, 250 V AC / 10 A, 400 V AC
- cos φ		See next page
Mechanical life (cycles)		>10 <sup>7</sup>
Dimensions		36,1 x 38,6 x 45,5 mm
<b>Ambient temperature</b>		
- storage		- 40...+85°C
- operating		- 40...+55°C
Cover protection category		IP 00
Environmental protection		RTI
Shock resistance (NO/NC)		10 g
Vibration resistance		5g 10...150 Hz
Solder bath temperature		max. 270°C
Soldering time		max. 5s

**Table 2: Coil data**

Coil code	Rated voltage V AC	Coil resistance at 20 °C Ω	Acceptable resistance	Coil operating range V AC	
				min. (at 20 °C)	max. (at 55 °C)
024AC	24	75	± 15%	19,2	26,4
230AC	230	7080	± 15%	184,0	253,0

**Dimensions**

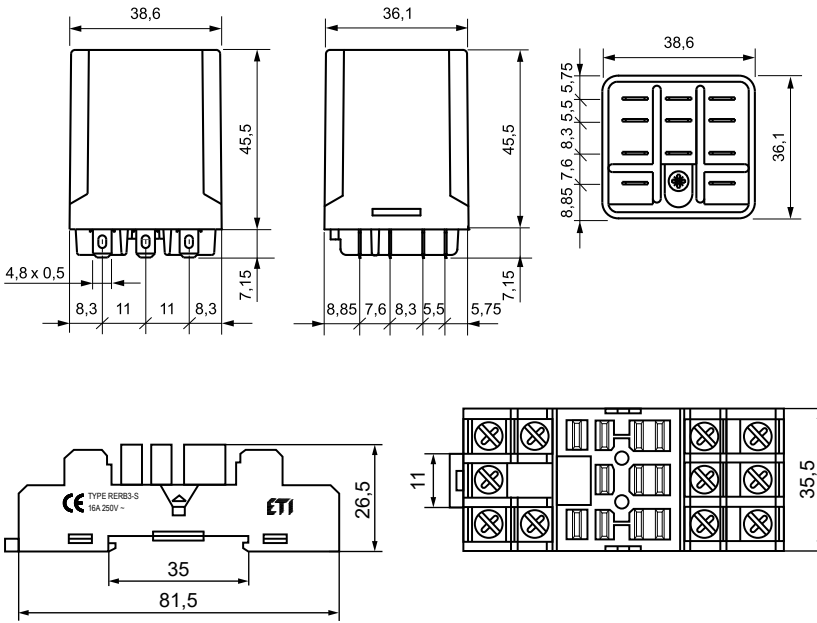

**Connection diagram (pin side view)**

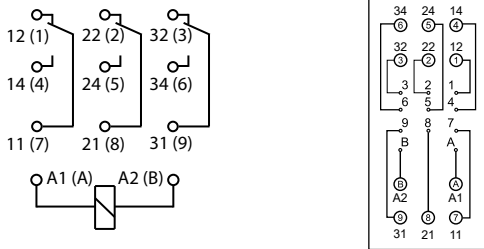

**Electrical life at AC resistive load.**  
Switching frequency: 1 200 cycles/hour

**Electrical life reduction factor at AC inductive load**

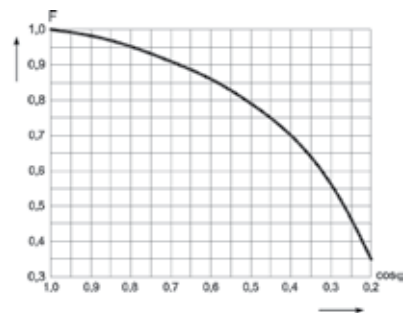
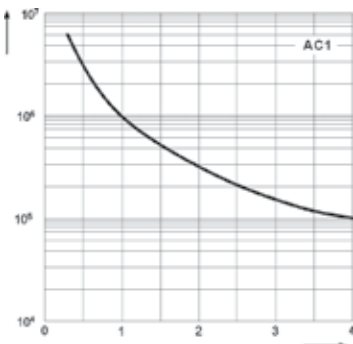

## Industrial Plugin Electromagnetic Relays

### Description

Relays of general application - the new relays are distinguished by a modern design, high reliability and functionality. Modern technology ensures high quality and effectiveness

- // ERM2 (2 pole CO »change over contact«) and ERM4 (4 pole CO »change over contact«)
- // AC and DC coils (12, 24V), 230V AC only
- // Two types of plug-in sockets (M type and T type)
- // Accessories ( connection terminals, retainer/retractor clips, description plates, RC modules...)
- // Colour: grey

### Features

- // Mechanical indicator with lockable test button as a standard version
- // Optional: Light indication (with built in smd LED)
- // Mounting on panel or 35 mm rail in accordance with EN60715
- // Improved electromagnet efficiency
- // Strong insulation between contacts ( applied polyamide PA66)
- // Cadmium - free contacts
- // Miniature dimensions
- // Recognitions, certifications, directives: RoHS, CE
- // Standards: EN61810-1:2008 (electromechanical relays); EN61984:2002, EN60998-2-1:2001, EN60664-1:2003 (sockets)

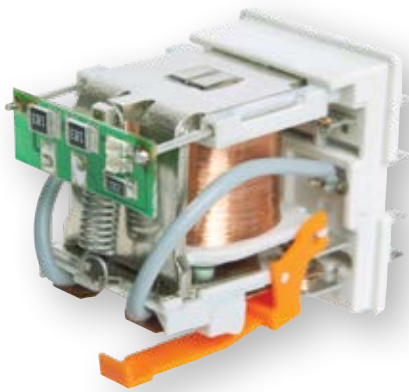

Robust design

### Test buttons

green - DC coils



orange - AC coils



Protecting module ERC



Electromagnetic relay ERM

Retainer / retractor clip - ER-CLIP



Screw terminals plug-in socket ERB

Description plate ER-PLATE





\*All parts must be ordered separately

Table 1: Technical data

		ERM2	ERM4
Number and type of contacts		2 C0	4 C0
Contact material		AgNi	
Rated / max. switching voltage AC		250 V / 440 V	250 V / 250 V
Min. switching voltage		10 V	10 V AgNi, 10 V AgNi/Au 0,2 µm, 5 V AgNi/Au 5 µm
Rated load (capacity)	AC1	12 A / 250 V AC	6 A / 250 V AC
	AC15	3 A / 120 V 1,5 A / 240 V	1,5 A / 120 V 0,75 A / 240 V (C300)
	AC3	370 W (single-phase motor)	125 W (single-phase motor)
	DC1	12 A / 24 V DC (see Fig. 3)	6 A / 24 V DC (see Fig. 3)
	DC13	0,22 A / 120 V 0,1 A / 250 V	0,22 A / 120 V 0,1 A / 250 V (R300)
Min. switching current		5 mA	
Max. inrush current		24 A	12 A
Rated current		12 A	6 A
Max. breaking capacity		AC1 3 000 VA	1 500 VA
Min. breaking capacity		0,3 W	0,3 W AgNi, 0,3 W AgNi/Au 0,2 µm, 0,1 W AgNi/Au 5 µm
Contact resistance		≤ 100 mΩ	
Max. operating frequency (cycles/hour)			
• at rated load		AC1 1 200	
• no load		18 000	
Coil data			
Rated voltage 50/60 Hz AC DC		See table 2	
Must release voltage		AC: ≥ 0,2 Un	DC: ≥ 0,1 Un
Operating range of supply voltage		see Table 2	
Rated power consumption		AC 1,6 VA	DC 0,9 W
Insulation according to EN 60664-1			
Insulation rated voltage		250 V AC	
Rated surge voltage		4 000 V 1,2 / 50 µs	2 500 V 1,2 / 50 µs
Overvoltage category		III	II
Insulation pollution degree		3	2
Dielectric strength			
• between coil and contacts		2 500 V AC	type of insulation: basic
• contact clearance		1 500 V AC	type of clearance: micro-disconnection
• pole - pole		2 500 V AC	type of insulation: basic
Contact - coil distance			
• clearance		≥ 2,5 mm	≥ 1,6 mm
• creepage		≥ 4 mm	≥ 3,2 mm
General data			
Operating / release time (typical values)		AC: 10 ms / 8 ms	DC: 13 ms / 3 ms
Electrical life			
• resistive AC1		> 10 <sup>5</sup> 12 A, 250 V AC	> 10 <sup>5</sup> 6 A, 250 V AC
• cosΦ		see Fig. 2	see Fig. 2
Mechanical life (cycles)		> 2 x 10 <sup>7</sup>	
Dimensions (L x W x H)		27,5 x 21,2 x 35,6 mm	
Weight		35 g	
Ambient temperature			
• storage		-40...+85 °C	
• operating		AC: -40...+55 °C	DC: -40...+70 °C
Cover protection category		IP 40	EN 60529
Environmental protection		RTI	EN 116000-3
Shock resistance (NO/NC)		10 g / 5 g	
Vibration resistance		5 g 10...150 Hz	

**Electromagnetic Plugin Relays with Mechanical Indication and Lockable Test Button**

Type	Code	Uc rated coil voltage [V]	No. Of contacts	 g	
ERM4-012DCL	002473021	12 V DC	4 x CO (6A, AC1)	33	10/100
ERM2-024DC	002473000	24 V DC	2 x CO (12A, AC1)	33	10/100
ERM2-024DCL	002473001	24 V DC	2 x CO (12A, AC1)	33	10/100
ERM2-024AC	002473002	24 V AC	2 x CO (12A, AC1)	33	10/100
ERM2-024ACL	002473003	24 V AC	2 x CO (12A, AC1)	33	10/100
ERM2-230AC	002473004	230 V AC	2 x CO (12A, AC1)	33	10/100
ERM2-230ACL	002473005	230 V AC	2 x CO (12A, AC1)	33	10/100
ERM4-024DC	002473006	24 V DC	4x CO (6A, AC1)	33	10/100
ERM4-024DCL	002473007	24 V DC	4x CO (6A, AC1)	33	10/100
ERM4-024AC	002473008	24 V AC	4x CO (6A, AC1)	33	10/100
ERM4-024ACL	002473009	24 V AC	4x CO (6A, AC1)	33	10/100
ERM4-230AC	002473010	230 V AC	4x CO (6A, AC1)	33	10/100
ERM4-230ACL	002473011	230 V AC	4x CO (6A, AC1)	33	10/100

\*L - built in LED light indicator (red)

Other coil (control) voltages available upon special request:

V DC: 5, 6, 48, 60, 80, 110, 220

V AC: 6, 12, 42, 48, 60, 80, 110, 115, 120, 127, 220, 240



**Ordering designation**

ERMX-YYYYYZ

X – Number of contacts:  
4: 4 CO (4 changeover)  
2: 2 CO (2 changeover)

YYYYY – Coil code:  
024AC: 24 V AC 50/60 Hz  
230AC: 230 V AC 50/60 Hz  
024DC: 24 V DC  
012DC: 12 V DC

Z – Additional features:  
L – Light indicator (smd LED - red)

Example:  
ERM4-024DCL Electromagnetic relay for plugin sockets with mechanical indication and lockable test button, four changeover contacts, coil voltage 24 V DC with light indicator.



**Meaning of color codes:**

green - DC coils

orange - AC coils



**Plug-in Sockets (Base)**

Type	Code	For use with	 g	
ERB2-T	002473012	ERM2	60	10/100
ERB2-M	002473013	ERM2	71	10/80
ERB4-T	002473014	ERM4	60	10/100
ERB4-M	002473015	ERM4	71	10/80

T - T type

M - M type





ERB2-T, ERB4-T



ERB2-M, ERB4-M

**Accessories**

Type	Code	For use with		
ER-CLIP	002473016	ERB-T & ERB-M	4,5	10/300
ER-PLATE	002473017	ERB-T & ERB-M	0,5	50/500
ER-TERMINAL	002473018	ERB-T & ERB-M	1,3	2/20
ERC-024AC	002473019	ERB-T & ERB-M $U_c \leq 24V$ AC	2,6	20/100
ERC-230AC	002473020	ERB-T & ERB-M $U_c \leq 230V$ AC	2,6	20/100
ERC-024ACDCL	002473040	ERB-T & ERB-M $U_c = 6 \dots 24V$ AC/DC	2,9	20/100
ERC-060ACDCL	002473041	ERB-T & ERB-M $U_c = 24 \dots 60V$ AC/DC	2,9	20/100
ERC-230ACDCL	002473042	ERB-T & ERB-M $U_c = 110 \dots 230V$ AC/DC	2,9	20/100



ER-CLIP  
Mechanical lock of relay in socket

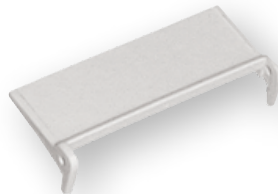

ER-PLATE  
description

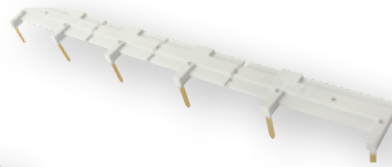

ER-TERMINAL  
bridges common input signals (coil terminals  
A1 or A2) up to 6 relays



ERC  
protection module



ERC-(024...230)ACDCL  
MOV protection module with indication AC and DC.

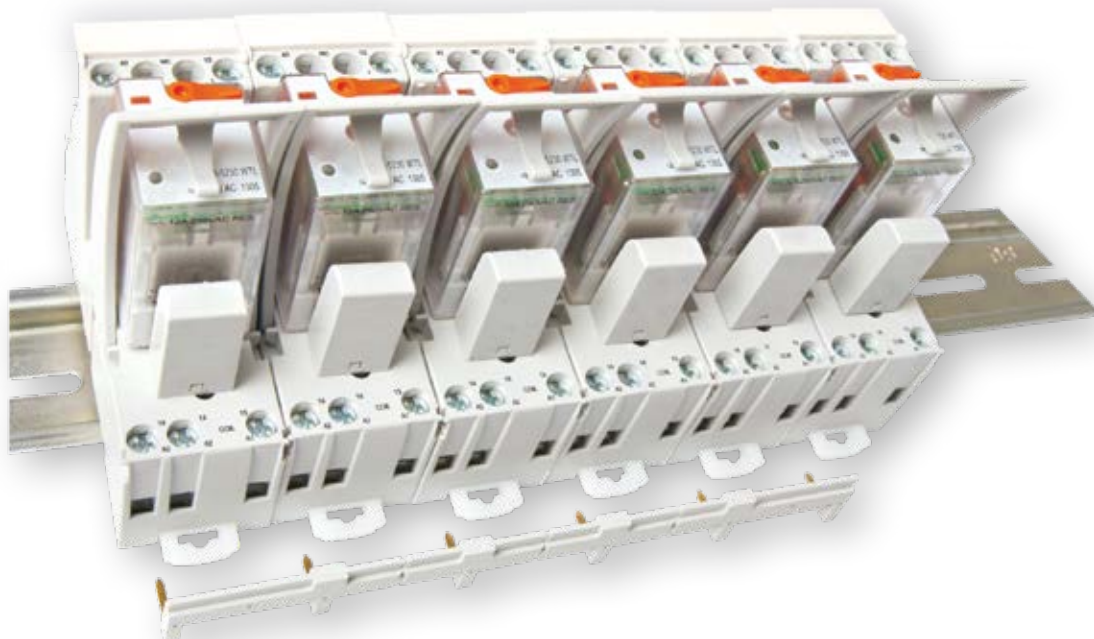

**Table 2: Coil data**

DC voltage version					
Coil code	Rated voltage V DC	Coil resistance at 20 °C Ω	Acceptable resistance	Coil operating range V DC	
				min. (at 20 °C)	max. (at 20 °C)
012DC	12	160	± 10%	9,6	21,6
024DC 024DC	24	640	± 10%	19,2	45,4
048DC	48	2600	± 10%	38,4	86,4
110DC	110	13600	± 10%	88	198
220DC	220	54000	± 10%	176	250

AC voltage version					
Coil code	Rated voltage V AC	Coil resistance at 20 °C Ω	Acceptable resistance	Coil operating range V AC	
				min. (at 20 °C)	max. (at 20 °C)
024AC	24	158	± 10%	19,2	25,3
230AC	230	16100	± 10%	184,0	253

**Dimensions**

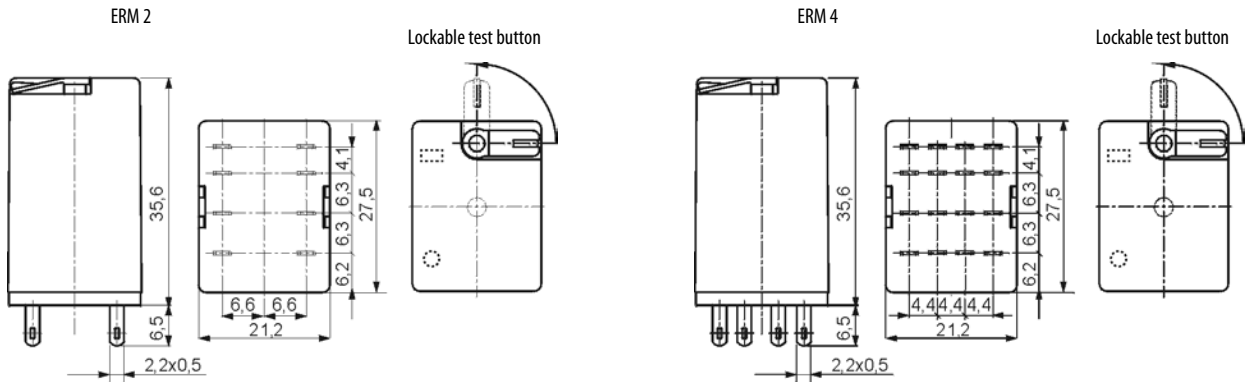

**Connection diagram (pin side view)**



Electrical life at AC resistive load. Switching frequency: 1 200 cycles/hour Fig. 1

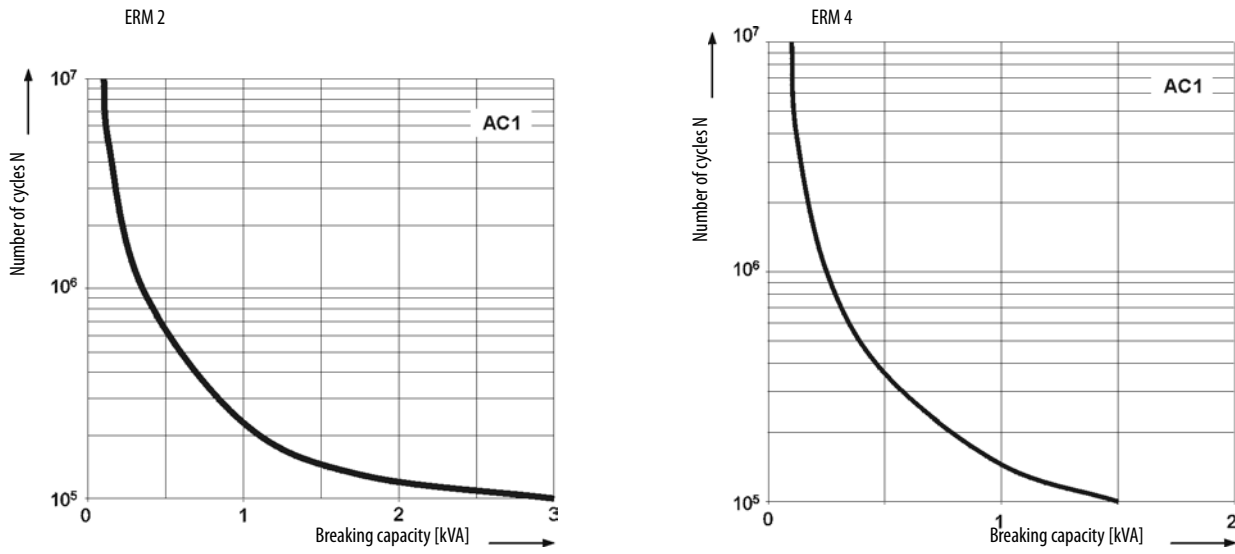

Electrical life reduction factor at AC inductive load Fig. 2

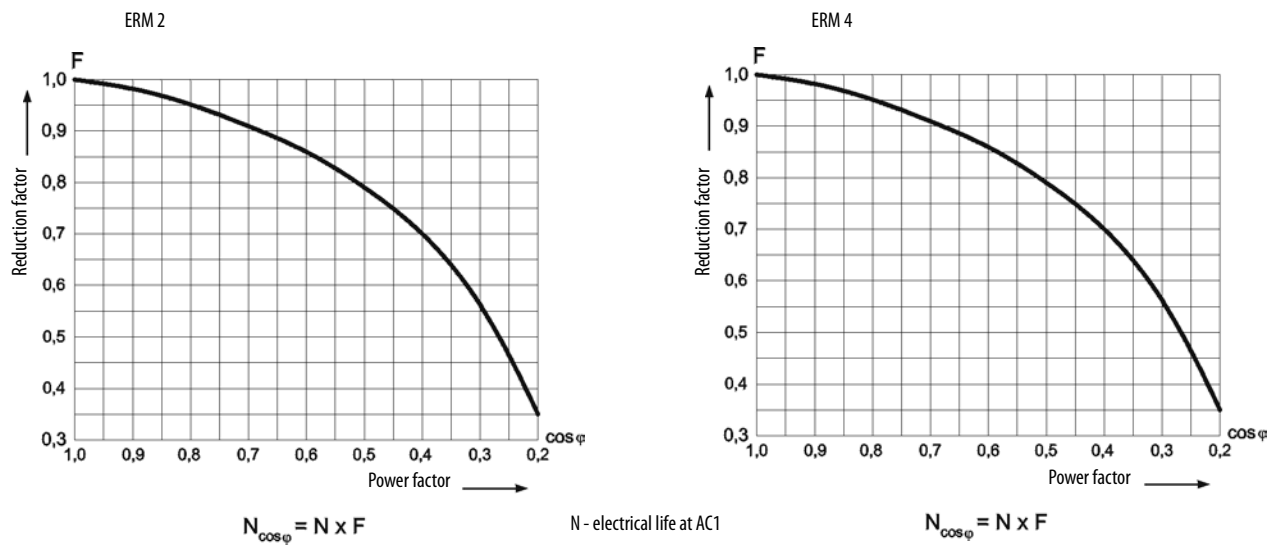

Max. DC resistive load breaking capacity Fig. 3

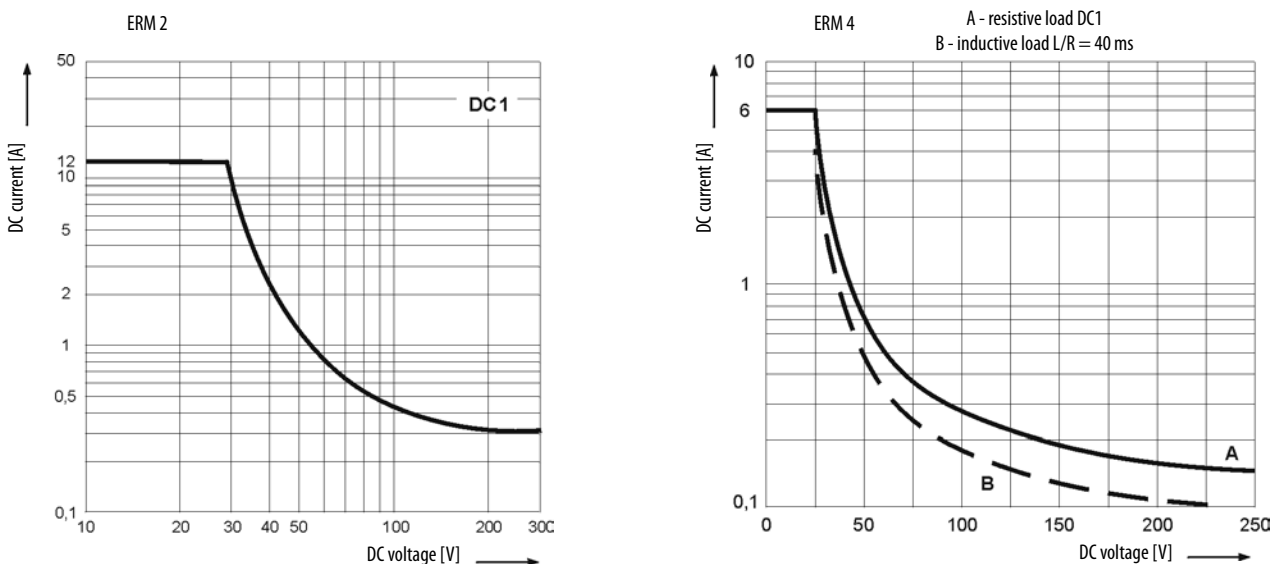

## Contact material selection for different load types ERM2 and ERM4

AgNi - for resistive or inductive loads,

## Mounting

### ERM 2

Relays ERM2 are designed for mounting in plug-in sockets, standard version includes mechanical indicator with lockable front test button.

Relays ERM2 are designed for:

- // screw terminals plug-in
- // sockets ERB2-T\*
- // sockets ERB2-M\* with clip ER-CLIP
- // 35 mm rail mount acc. to EN 60715 or
- // panel mounting

protecting modules type ERC are available as accessories /sockets (see below)

\*Plug-in sockets ERB2-T and ERB2-M may be linked with interconnection strip type ER-TERMINAL

### ERM 4

Relays ERM4 are designed for mounting in plug-in sockets, standard version includes mechanical indicator with lockable front test button.

Relays ERM4 are designed for:

- // screw terminals plug-in
- // sockets ERB4-T\*
- // sockets ERB4-M\* with clip ER-CLIP
- // 35 mm rail mount acc. to EN 60715 or
- // panel mounting

protecting modules type ERC are available as accessories /sockets (see below)

\*Plug-in sockets ERB4-T and ERB4-M may be linked with interconnection strip type ER-TERMINAL

## Plugin Sockets And Accessories

### ERB2-T and ERB4-T Plug-in sockets (base) type T

- // Screw terminals
- // Max. tightening moment for the terminal: 0,7 Nm
- // 35 mm rail mount acc. to EN 60715
- // or on panel mounting
- // 76,3 x 27 x 42,5(80) mm\*

\*In the bracket the height of socket with retainer / retractor clip is shown.

**Two poles**  
12A, 300 V AC  
For ERM2

**Four poles**  
6A, 300 V AC  
For ERM4

### Connection diagram

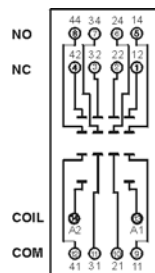
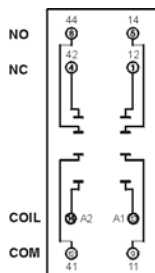

### Dimensions

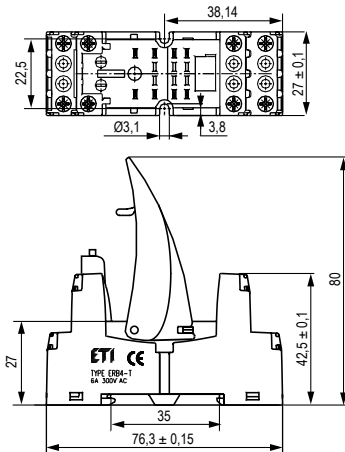

**ERB2-M and ERB4-M  
Plug-in sockets (base) type M**

- /// Screw terminals
- /// Max. tightening moment for the terminal: 0,7 Nm
- /// 35 mm rail mount acc. to EN 60715
- /// or on panel mounting
- /// 75 x 27 x 61(82) mm\*

\*In the bracket the height of socket with retainer / retractor clip is shown.

**Two poles**  
12A, 300 V AC  
For ERM2

**Four poles**  
6A, 300 V AC  
For ERM4

**Dimensions**

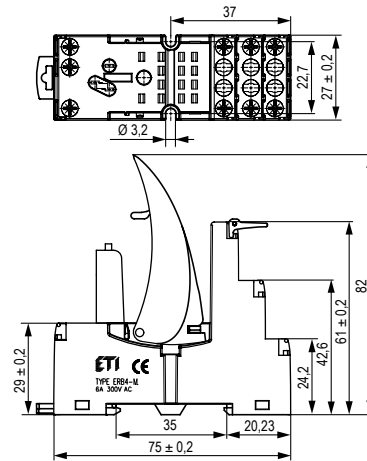

**Connection diagram**

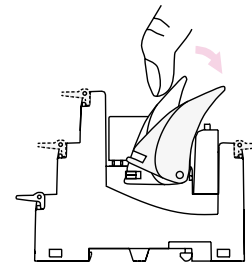
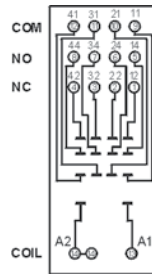
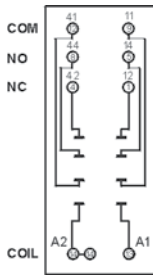

Removing the relay from the socket with a retractor / retractor clip

**Protection RC modules type ERC\_AC**

It protects against EMC disturbance and limits overvoltage.

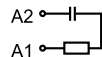

6/24 V AC	ERC-024AC
110/240 V AC	ERC-230AC

**Protection RC modules type ERC\_ACDCL**

It limits overvoltage on AC and DC coils. Coil energizing indication.

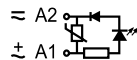

6...24 V ACDC	ERC-024ACDCL
24...60 V AC DC	ERC-060ACDCL
110...230 V ACDC	ERC-230ACDCL



Modules are parallelly connected with relay coil

**Interconnection strip ER-CLIP**

designed for the co-operation with plug-in sockets ERB of miniature industrial relays, which are equipped with screw terminals; sockets and relays are mounted on 35 mm rail mount acc. to EN 60715.

- /// bridges common input signals (coil terminals A1 or A2)
- /// maximum permissible current is 10 A / 250 V AC,
- /// possibility of connection of 6 sockets or relays

**Dimensions**

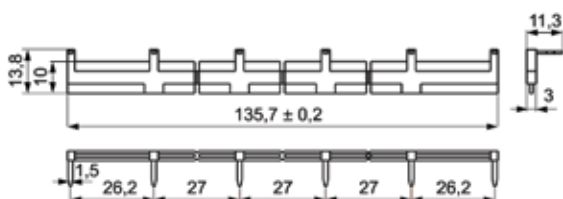

## Miniature Electromagnetic Relays

### Description

Electromechanical relay with 2x CO contacts in miniature housing. Can be used in PCB or with plug-in sockets.

- // MER2 (2 pole CO »change over contact«, 2x8A AC1)
- // Wide range of control voltages ( AC coils: 24V and 230V, DC coils: 5V, 12V, 24V)
- // Two types of plugin sockets (M type and T type)
- // Accessories (retainer/retractor clips, RC modules...)
- // Color: Grey

### Features

- // Cadmium - free contacts; height 15,7 mm
- // 5000V / 10 mm reinforced insulation
- // For PCB and plug-in sockets
- // AC and DC coils
- // Compliance with standard EN 60335-1
- // RoHS



Miniature electromechanical relay MER



Retainer / retractor clip - MER-CLIP-PL



Description plate MER-PLATE

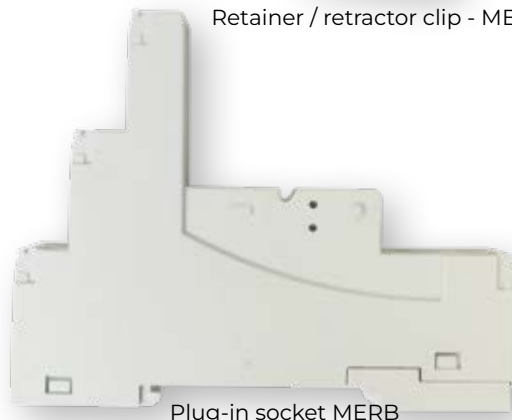

Plug-in socket MERB





Protecting module ERC

\*All parts must be ordered separately

Table 1: Technical data

		MER2
Number and type of contacts		2 CO
Contact material		AgNi
Rated / max. switching voltage AC		250 V / 440 V
Min. switching voltage		5 V AgNi
Rated load (capacity)		
AC1		8 A / 250 V AC
AC15		3 A / 120 V 1,5 A / 240 V (B300)
AC3		550 W (single-phase motor)
DC1		8 A / 24 V DC (see Fig. 3)
DC13		0,22 A / 120 V 0,1 A / 250 V (R300)
Min. switching current		5 mA AgNi
Rated current		8 A
Max. breaking capacity AC1		2000 VA
Min. breaking capacity		0,3 W AgNi
Contact resistance		≤ 100 mΩ
Max. operating frequency (cycles/hour)		
• at rated load AC1		600
• no load		72 000
Coil data		
Rated voltage 50/60 Hz AC		12 ... 240 V
DC		3 ... 110 V
Must release voltage		AC: ≥ 0,15 U <sub>n</sub> DC: ≥ 0,1 U <sub>n</sub>
Operating range of supply voltage		See Tables 1, 2 and Fig. 4, 5
Rated power consumption AC		0,75 VA
DC		0,4 ... 0,48 W
Insulation according to EN 60664-1		
Insulation rated voltage		400 V AC
Rated surge voltage		4000 V 1,2 / 50 μs
Overvoltage category		III
Insulation pollution degree		3
Dielectric strength		
• between coil and contacts		5000 V AC type of insulation: reinforced
• pole - pole		2500 V AC type of insulation: basic
Contact - coil distance		
• clearance		≥ 10 mm
• creepage		≥ 10 mm
General data		
Operating / release time (typical values)		7 ms / 3 ms
Electrical life		
• resistive AC1		> 10 <sup>5</sup> 8 A, 250 V AC
• cosΦ		see Fig. 2
• DC L/R = 40 ms		> 10 <sup>5</sup> 0,15 A, 220 V DC
Mechanical life (cycles)		> 3x10 <sup>7</sup>
Dimensions (L x W x H)		29 x 12,7 x 15,7 mm
Weight		14 g
Ambient temperature		
• storage		-40 ... +85 °C
• operating		AC: -40 ... +70 °C DC: -40 ... +85 °C
Cover protection category		IP40 / IP67
Environmental protection		RTII / RTIII
Shock resistance (NC)		20 g
Vibration resistance		5 g 10 ... 150 Hz
Solder bath temperature/ soldering time		max. 270 °C / max. 5 s

**Miniature electromagnetic relays**

Type	Code	Uc rated coil voltage [V]	No. Of contacts		
MER2-005DC	002473030	5 V DC			
MER2-012DC	002473031	12 V DC			
MER2-024DC	002473032	24 V DC	2xCO (8A, AC1)	13	20/1000
MER2-024AC	002473033	24 V AC			
MER2-230AC	002473034	230 V AC			

By parallel connection of relay main circuit (joining 2 CO contacts), the nominal current of output is increased to 16A.  
 Other coil (control) voltages available upon special request:  
 V DC: 3, 6, 9, 18, 36, 48, 60, 110  
 V AC: 12, 48, 60, 110, 115, 120, 220, 240

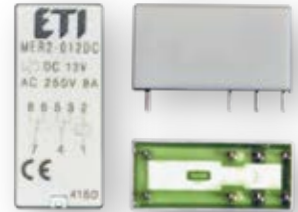

**Ordering designation**



MER2-YYYY

X – Number of contacts:                    024AC: 24 V AC 50/60 Hz  
 2: 2 CO (2 changeover)                    230AC: 230 V AC 50/60 Hz  
                                                           005DC: 5 V DC  
                                                           012DC: 12 V DC  
                                                           024DC: 24 V DC

YYYY – Coil code:

Example:  
 MER2-024DC  
 Miniature electromagnetic relay, two changeover contacts, coil voltage 24 V DC.

**Plug-in Sockets (Base)**

Type	Code	For use with		
MERB-T	002473035	MER2	44	10/100
MERB-M	002473036			10/80

T - T type  
 M - M type



Accessories

Type	Code	For use with	Single product weight [g]	Packaging [pcs]
MER-CLIP-SP	002473037			
MER-CLIP-PL	002473038	MERB-T & MERB-M	0,3	25/400
MER-PLATE	002473039		0,34	10/700
ERC-024AC	002473019	MER2-024AC	2,6	10/200
ERC-230AC	002473020	MER2-230AC		
ERC-024ACDCL	002473040	MERB-T & MERB-M $U_c = 6 \dots 24 \text{ V AC/DC}$	2,9	20/100
ERC-060ACDCL	002473041	MERB-T & MERB-M $U_c = 24 \dots 60 \text{ V AC/DC}$	2,9	20/100
ERC-230ACDCL	002473042	MERB-T & MERB-M $U_c = 110 \dots 230 \text{ V AC/DC}$	2,9	20/100
MER-TERMINAL	002473048	MERB-T, MERB-M	6	20/200



MER-CLIP-PL

Mechanical lock of relay in socket, two types  
Standard plastic MS and spring wire type



MER-CLIP-SP



MER-PLATE  
description



ERC  
protection module  
RC filter

\*More data about ERC module can be found on page 197.



ERC-(024...230)ACDCL

MOV protection module with indication AC and DC.  
\*More data about ERC module can be found on page 197.



MER-TERMINAL



Table 2: Coil data

DC voltage version					
Coil code	Rated voltage V DC	Coil resistance at 20 °C Ω	Acceptable resistance	Coil operating range V DC	
				min. (at 20 °C)	max. (at 20 °C)
005DC	5	60	± 10%	3,5	12,7
012DC	12	360	± 10%	8,4	30,6
0240024DC	24 24	1440640	± 10%	16,819,2	61,226,4
AC 50/60 Hz voltage version					
024A024AC	24 24	400 158	± 10%	19,219,2	28,826,4
230A230AC	230 230	38 5006100	± 10%	184,084,0	276,053,0

Dimensions

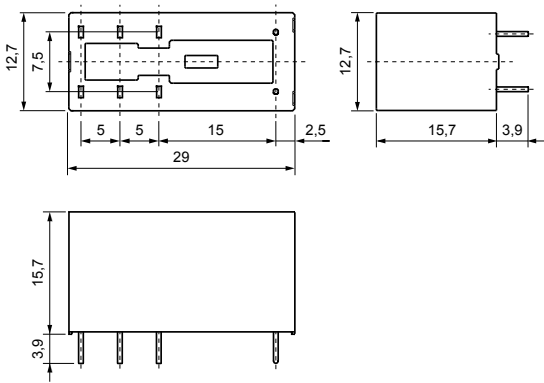

Connection diagram (pin side view)

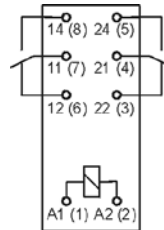

Terminal (pin)	A1(1); A2(2)	22(3); 21(4); 24(5); 12(6); 11(7); 14(8)
[mm]	Ø 0,6	0,5 x 0,9
Drilling hole:		
• for relays Ø 1,3 + 0,1 mm		
• for sockets Ø 1,5 + 0,1 mm		

Electrical life at AC resistive load.  
Switching frequency: 600 cycles/hour

Fig. 1

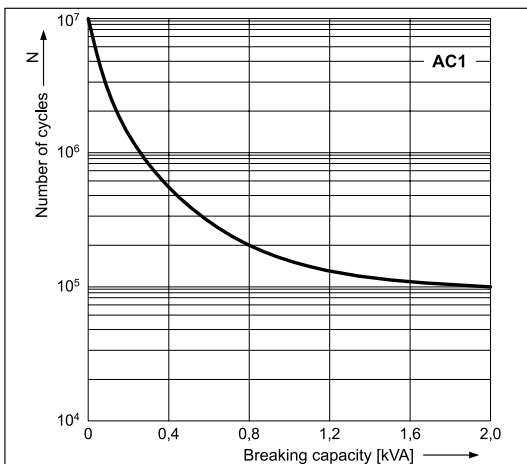

Electrical life reduction factor at  
AC inductive load

Fig. 2

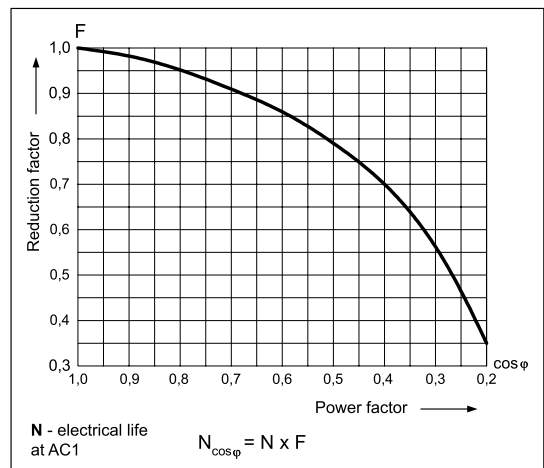

Max. DC resistive load breaking capacity Fig. 3

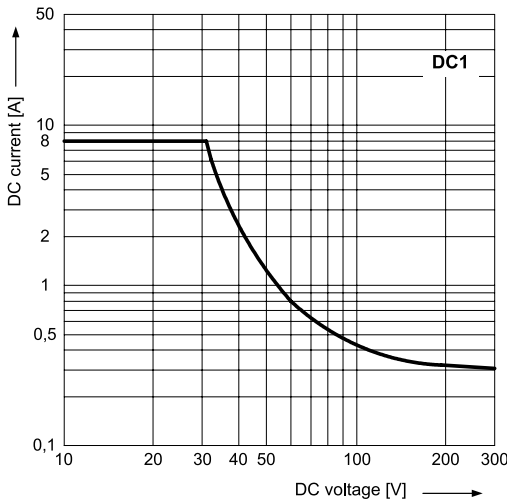

Coil operating range = DC Fig. 4

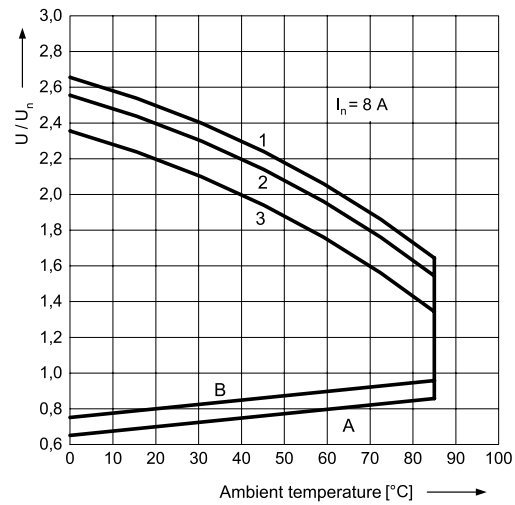

Coil operating range = AC 50 Hz Fig. 5

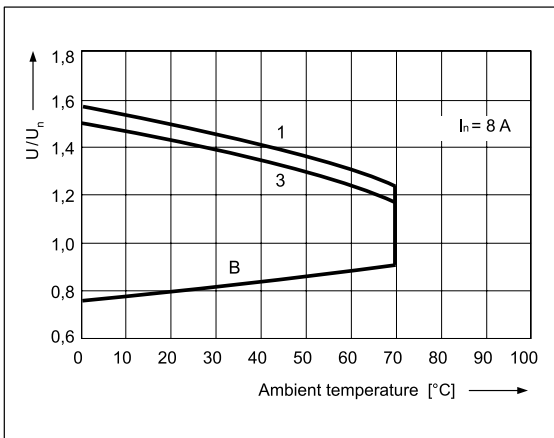

Description of Fig. 4 and 5

**A** - relations between make voltage and ambient temperature at no load on contacts. Coil temperature and ambient temperature are equal before coil energizing. Make voltage is not higher than the value read on Y axis (multiplication of rated voltage).

**B** - relations between make voltage and ambient temperature after initial coil heating up with  $1,1 U_n$  at continues load of  $I_n$  on contacts. Make voltage is not higher than the value read on Y axis (multiplication of rated voltage).

**1, 2, 3** - values on Y axis represent allowed overvoltage on coil at certain ambient temperature and contact load:

- 1 - no load
- 2 - 50% of rated load

Pinout (soldier side view)

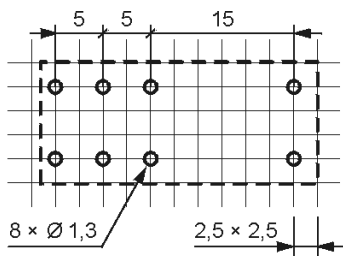

Mounting

Relays MER2 are designed for:  
 direct PCB mounting  
 screw terminals plug-in sockets MERB-T and MERB-M

Plugin Sockets And Accessories

**MERB-T**  
Plugin sockets (base) type T

- // Screw terminals
- // Max. tightening moment for the terminal: 0,7 Nm
- // 35 mm rail mount acc. to EN 60715
- // or on panel mounting
- // 75,3 x 15,5 x 61(67) mm\*

\*In the bracket the height of socket with retainer / retractor clip is shown.

Two poles, 5mm pinout  
12A, 300 V AC  
Dimensions

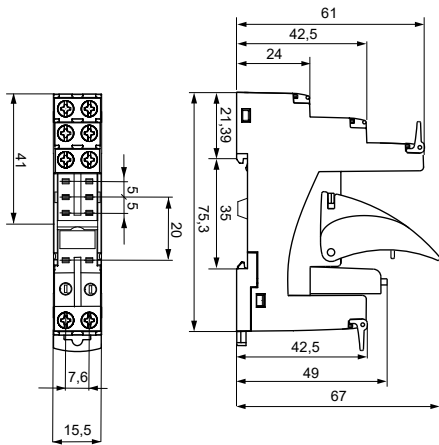

Connection diagram

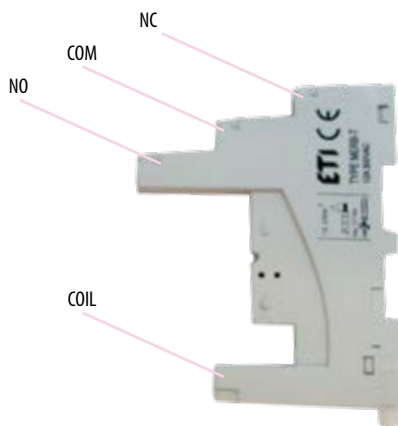
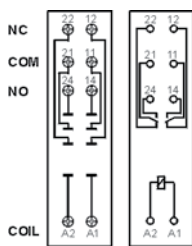

**MERB-M**  
Plugin sockets (base) type M

- // Screw terminals
- // Max. tightening moment for the terminal: 0,7 Nm
- // 35 mm rail mount acc. to EN 60715
- // or on panel mounting
- // 78,1 x 15,9 x 61(66,5) mm\*

\*In the bracket the height of socket with retainer / retractor clip is shown.

Two poles, 5mm pinout  
12A, 300 V AC  
Dimensions

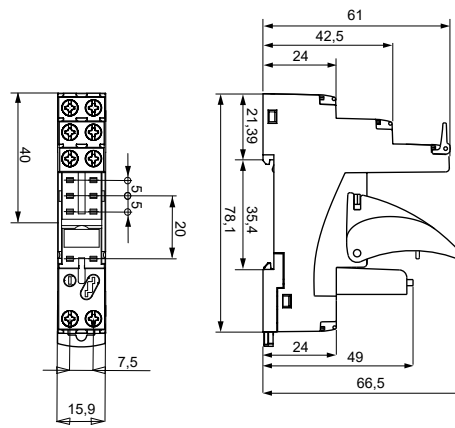

Connection diagram

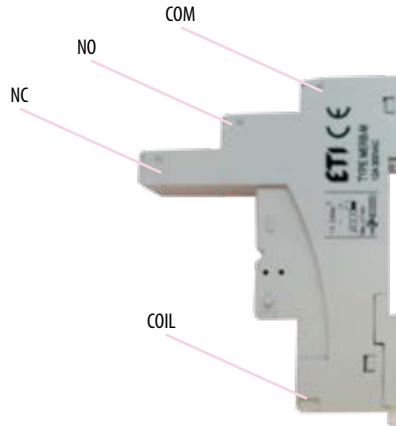
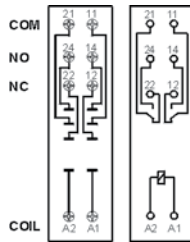

## SLIM RELAYS SSR &amp; SER, Electromagnetic and solid

Table 1: Technical data

	SER1; Contact data	SSR1; Output circuit - Triac
Number and type of contacts	1 CO	1 NO
Contact material	AgSnO2	-
Rated / max. switching voltage AC	400 V AC / 250 V DC	400 V AC / 440 V AC
Min. switching voltage	10 V AC / DC	20 V AC
Rated load (capacity)	AC1 DC1	
	6 A / 250 V AC 6 A / 24 V DC; 0,15 A / 250 V DC	1,2 A / 400 V AC -
Min. switching current	100 mA	10 mA
Max. inrush current / Max. non-repeat surge current	10 A (t=20 ms)	30 A (t=20 ms)
Rated current	6 A	16A
Max. breaking capacity AC1	1 500 VA	1 500 VA
Min. breaking capacity	1 W	-
Contact resistance	≤100 mΩ 100 mA, 24 V	-
Max. operating frequency (cycles/hour)		
• at rated load AC1	360	-
• no load	72 000	-
I <sup>2</sup> t for fusing	-	5,1 A <sup>2</sup> s (t=1-10 ms)
di/dt	-	50 A/μs
dV/dt	-	40 V/μs
Input circuit		
Rated voltage AC: 50/60 Hz AC/DC	24 V; 230 V	
Must release voltage / Turn-off voltage	AC: ≥ 0,2 Un DC: ≥ 0,1 Un	
Must operate voltage	AC & DC: ≤ 0,8 Un	-
Rated power consumption AC/DC	0,3 ... 1,6 VA / 0,3 ... 1,6 W	0,3 VA / 0,3 W 24 V AC/DC 1,6 VA / 1,6 W 230 V AC/DC
Insulation according to PN-EN 60664-1		
Insulation rated voltage	400 V AC	600 V AC
Rated surge voltage	4 000 V 1,2 / 50 μs	-
Overvoltage category	III	-
Insulation pollution degree	3	2
Dielectric strength		
• input - output	4 000 V AC 50/60 Hz, 1 min. (type of insulation: reinforced)	4 000 V AC 50/60 Hz, 1 min. (type of insulation: reinforced)
• input - output	6 000 V 1,2 / 50 μs	-
• mass - input, output	2 500 V AC 50/60 Hz, 1 min.	-
• contact clearance	1 000 V AC 50/60 Hz, 1 min. (type of clearance: micro-disconnection)	-
Input - output distance		
• clearance	≥ 6 mm	-
• creepage	≥ 8 mm	-
General data		
Operating / release time (typical values)		
Electrical life		
• resistive AC1 (cos φ = 0,4)	> 0,6 x 105 6 A, 250 V AC; > 2 x 105 2 A, 250 V AC	-
• resistive DC1	105 6 A, 30 V DC	-
Mechanical life (cycles)	> 2 x 107	-
Dimensions (L x W x H)	93,8 x 6,2 x 80 mm	
Weight	40 g	
Ambient temperature		
• storage	-40...+70 °C	-40...+70 °C
• operating	-40...+55 °C (-40...+60 °C 24 V DC)	-40...+55 °C
Protection category	IP 20 PN-EN 60529	
Environmental protection	RTI PN-EN 116000-3	
Shock resistance	10 g	
Vibration resistance	5 g 10...500 Hz	

### Advantages:

- // Width 6,2 mm;
- // Interface relay SER1 - with 1 CO contact output;
- // 35 mm rail mount acc. to PN-EN 60715;
- // May be linked with interconnection strip type SR-TERMINAL;
- // SR-TERMINAL;
- // Equipped in LED green;

### Mounting

Relays are designed for direct mounting on 35 mm rail mount acc. to PN-EN 60715. Connections: max. cross section of the cables: 1 x 2,5 mm<sup>2</sup> / 2 x 1,5 mm<sup>2</sup> (1 x 14 / 2 x 16 AWG), length of the cable deinsulation: 8 mm, max. tightening moment for the terminal: 0,3 Nm. Relays may be linked with interconnection strip type SR-TERMINAL bridges common input or output signals, maximum permissible current is 36 A / 250 V AC.

### Electromagnetic relays

Type	Code	Uc rated coil voltage [V]	No. Of contacts	I <sub>n</sub> [A]	g	Box
SER1-024ACDC	002473052	24 V AC/DC	1xCO	AC1: 6 A / 250 V DC1: 6A/24V; 0,15A/250 V	40	10/100
SER1-230ACDC	002473053	230 V AC/DC				



SER1-024ACDC

### Solid state relay (triac output)

Type	Code	Uc rated coil voltage [V]	No. Of contacts	I <sub>n</sub> [A]	g	Box
SSR1-024ACDC	002473050	24 V AC/DC	1xNO	AC1: 1,2 A/400 V	40	10/100
SSR1-230ACDC	002473051	230 V AC/DC				

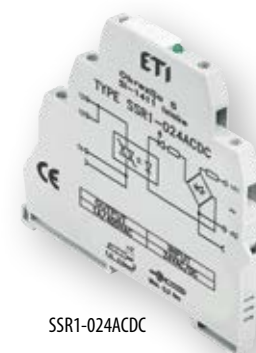

SSR1-024ACDC

### Accessories

Type	Code	Colour	Description	g	Box
SR-TERMINAL	002473054	black	max 36A (250VAC) or Max permissible current	12,3	10/100

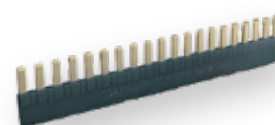

SR-TERMINAL



SR-TERMINAL: bridging of common input or output signals

**Input data SER1**

Interface relay code	Rated input voltage, Un	Power of input circuit	Input - voltage range, V	
			min. (20 °C)	max. (55 °C)
SER1-024ACDC	24 V AC/DC	0,5 VA / 0,5 W	19,2	26,4
SER1-230ACDC	230 V AC/DC	0,8 VA / 0,8 W	184,0	253,0

**Input data SSR1**

Interface relay code	Rated input voltage Un	Power of input circuit
SSR1-024ACDC	24 V AC/DC	0,3 VA / 0,3 W
SSR1-230ACDC	230 V AC/DC	1,6 VA / 1,6 W

**Dimensions**

**Connection diagram**

SER1-024ACDC / SER1-230ACDC

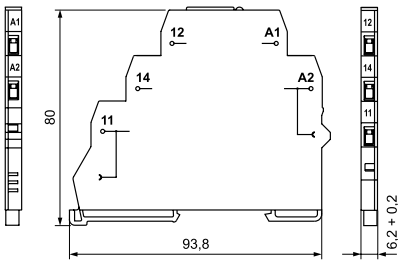

SER1-024ACDC

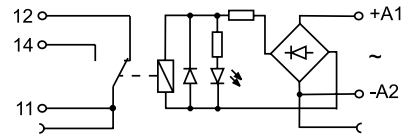

SER1-230ACDC

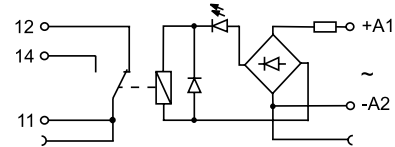

SSR1-024ACDC / SSR1-230ACDC

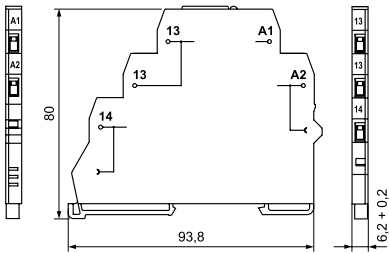

SSR1-024ACDC  
SSR1-230ACDC

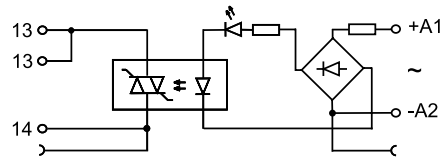

**SR-TERMINAL**

